

Owner's manual

Parts manual

800cc SHOP MANUAL

READ THIS MANUAL CAREFULLY
IT CONTAINS IMPORTANT SAFETY INFORMATION.

ORDER PARTS

<https://gokartsusa.com/800cc-Go-Kart-Buggy-Engine.aspx>

MINIMUM
RECOMMENDED
OPERATOR AGE

16



FOR OFF-ROAD USE ONLY

This vehicle is designed and manufactured for off-road use only.

USA only;

It does not conform to federal motor vehicle safety standards, and operation on public streets, roads, or highways is illegal

ALTERNATOR

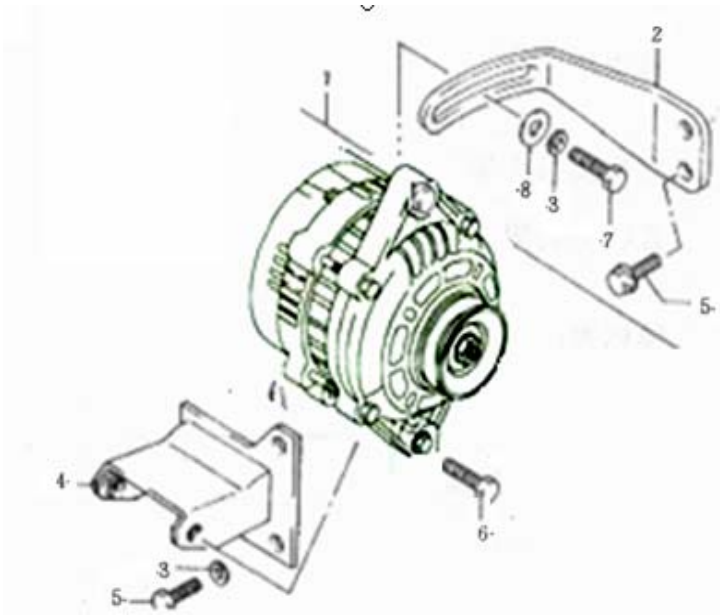

No.	Code name	Description	Qty	P/T
1	3701010	ALTERNATOR	1	
2	1000021D	ARM-GEN,BELT ADJ	1	
3	1000019D	WASHER	6	
4	1000102D	BRACKET-ALTERNATOR	1	
5	GB5783-1986	BOLT(M8x25)	5	
6	1000089D	BOLT(M8x30)	2	
7	1000089D	BOLT(M8x30)	1	
8	GB97.1-1985	WASHER	1	



ORDER PARTS

<https://gokartsusa.com/800cc-Go-Kart-Buggy-Engine.aspx>

IGNITION CABLE

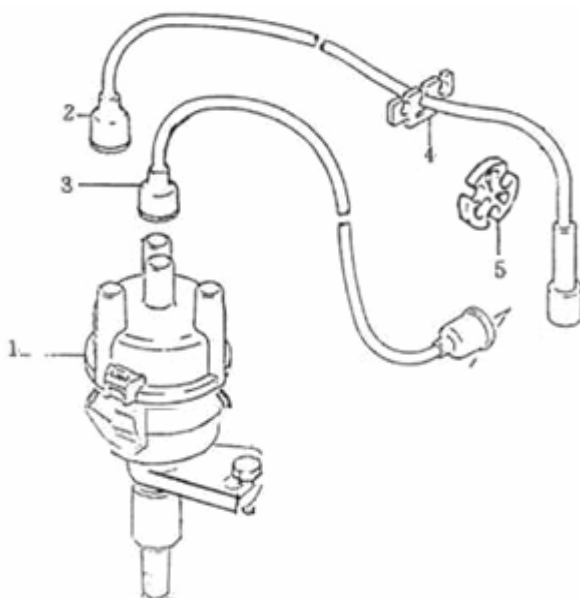

No.	Code name	Description	Qty
1	3706010	DISTRIBUTOR ASSY	1
2	3707011	WIRE A-HIGH TENSION,MID	1
3	3707012	WIRE A-HIGH TENSION	3
4	1000076	CLAMP-HT CORD	1
5	1000172	CIRCLE CLAMP-HT CORD	1

CYLINDER HEAD

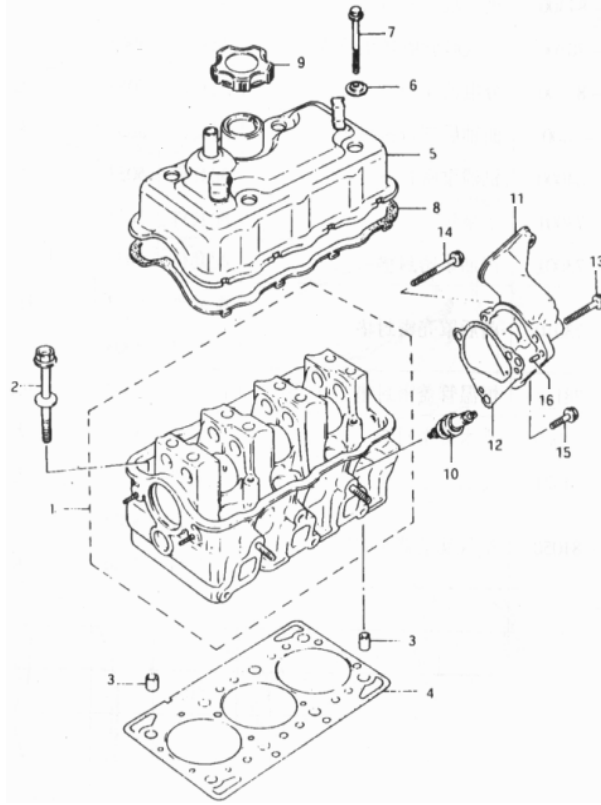

No.	Code name	Description	Qty	P/T
1	1003010	CYLINDER HEAD	1	
2	1000031D	BOLT (M10x1.25x87)	8	
3	1000028D	KNOCK PIN	2	
4	1003070	GASKET-CYLINDER HEAD	1	
5	1003051	COVER -CYLINDER HEAD	1	
6	1000061D	GASKET-BOLT	4	
7	1000059D	BOLT (M6x68)	4	
8	1003064	GASKET-COVER	1	
9	1003052	CAP COMP-OIL FILLER	1	
10	GB7828-87	SPARK	3	
11	1000038	CASE -DISTRIBUTOR	1	
12	1000035D	GASKET-DISTRIBUTOR CASE	1	
13	1000171	BOLT (M8x45)	1	
14	1000087D	BOLT (M8x60)	1	

OIL PUMP

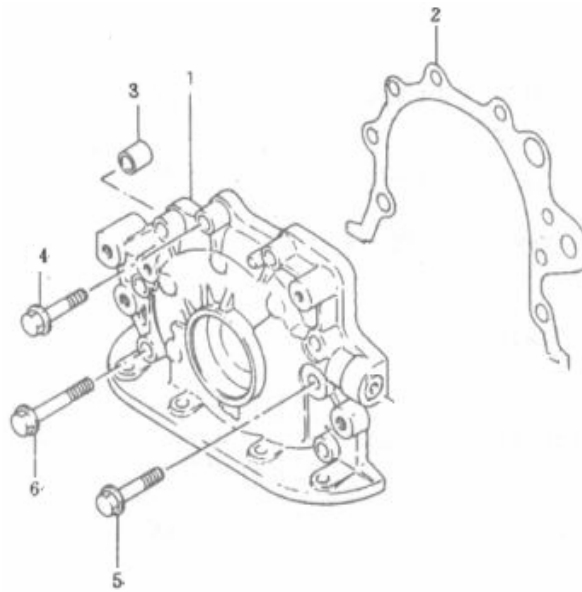

No.	Code name	Description	Qty	P/T
1	1011010D	PUMP A-OIL	1	
2	1000051D	GASKET-OIL PUMP CASE	1	
3	1000014D	KNOCK PIN	1	
4	1000083D	BOLT(M6×30)	1	
5	1000084D	BOLT(M6×35)	5	
6	1000085D	BOLT(M6×40)	2	

INTAKE MANIFOLD

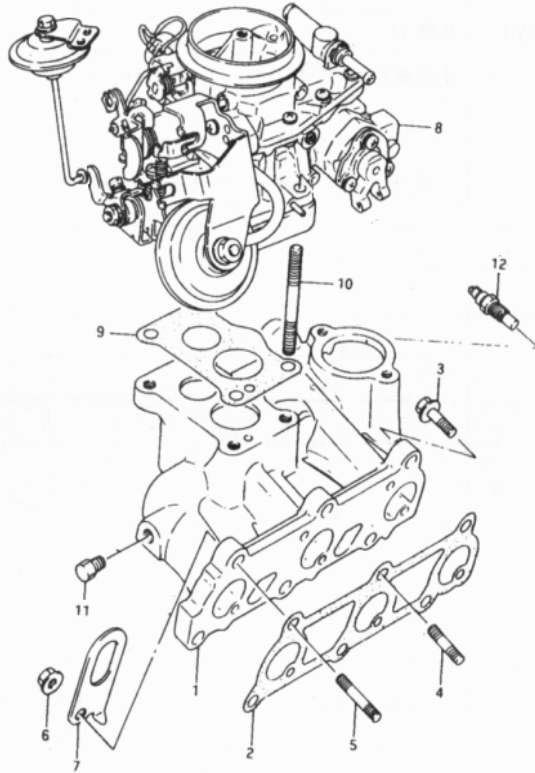

No.	Code name	Description	Qty	P/T
1	1008026(G)	MANIFOLD-INTAKE	1	
2	1000063	GASKET-INTAKE MANIFOLD	1	
3	1000162	BOLT	4	
4	1000090D	STUD BOLT(M8-M8x22)	5	
5	1000093D	STUD BOLT(M8-M8x25)	1	
6	Q340B08	NUT	5	
7	1000027	HOOK-ENGINE	1	
8	1107010	CARBURETOR ASSY	1	
9	1000022	GASKET-CARBURETOR	1	
10	1008035	STUD BOLT(M8-M8x37)	4	
11	1008050	PLUG	1	
12	3808010	GAIGE WATERTEMPERATURE	1	

COOLING

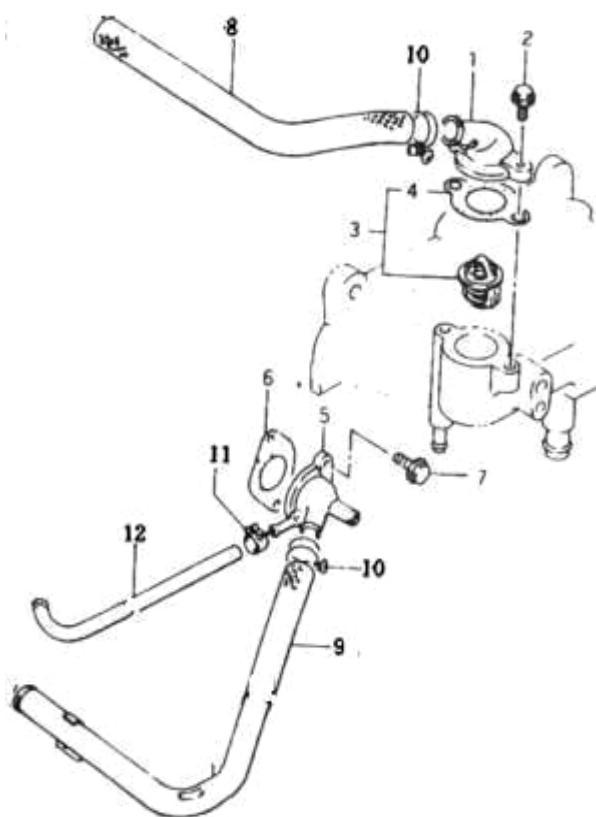

NO.	CODE NAME	Description	QTY	PT
1	1008029	CAP-WATER THERMOSTAT	1	
2	1000073D	BOLT	2	
3	1306010	THERMOSTAT-WATER	1	
4	1008031	GASKET-CAP	1	
5	1303013	PIPE-WATER INLET	1	
6	1000025D	GASKET-WATER INLET	1	
7	1000081D	BOLT	2	
8	1000151	HOSE-RADIATOR WATER EXHAUST	1	
9	1000165	HOSE-WATER INLET PIPE	1	
10		CLIP	2	
11	1000044D	CLIP	2	
12	1000043	HOSE	1	

CLUTCH

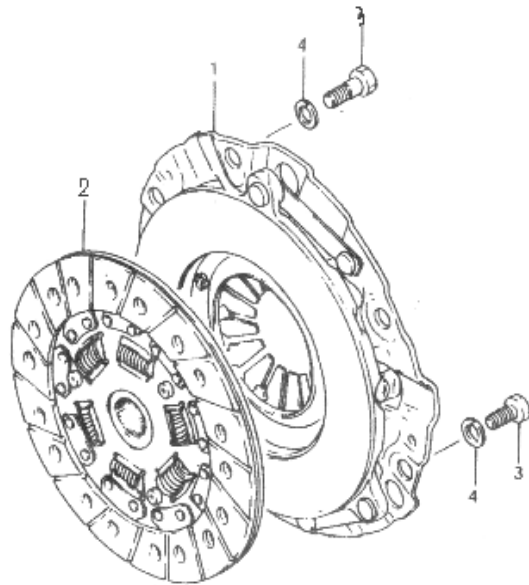

No.	Code name	Description	Qty
1	1600010	COVER ASSY-CLUTCH	1
2	1602010	DISK -CHUTCH	1
3	GB5783-1986	REAMER BOLT(8x20)	4
4	GB93-1987	LOCK WASHER	4

GASKET

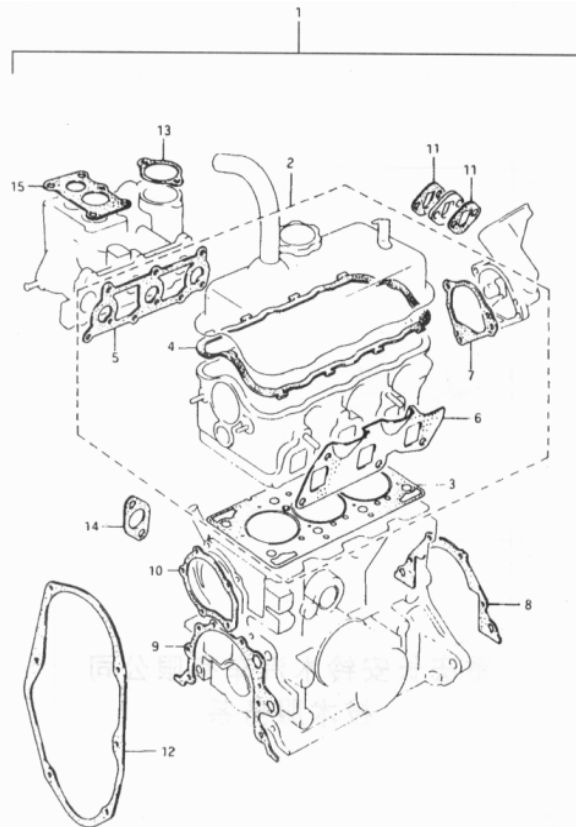

No.	Code name	Description	Qty	P/T
1		GASKET, all		
2				
3	1003070	GASKET-CYLINDER HEAD	1	
4	1003064	GASKET-COVER	1	
5	1000063	GASKET-INTAKE MANIFOLD	1	
6	1000054	GASKET-EXHAUST MANIFOLD	1	
7	1000035D	GASKET-DISTRIBUTOR CASE	1	
8	1002030D	GASKET-HOUSING	1	
9	1000051D	GASKET-OIL PUMP CASE	1	
10	1000052D	GASKET-WATER PUMP	1	
11	1000036D	GASKET-GASOLINE PUMP	1	
12	1000029D	GASKET-COVER	1	

OIL PAN

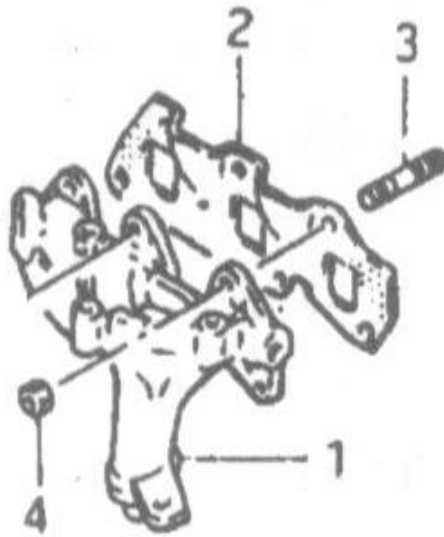

No.	Code name	Description	Qty
1	1008010	MANIFOLD-EXHAUST	1
2	1000054	GASKET-EXHAUST MANIFOLD	1
3	1000090D	STUD BOLT	6
4	GB6170-1986	NUT	6

STARTER

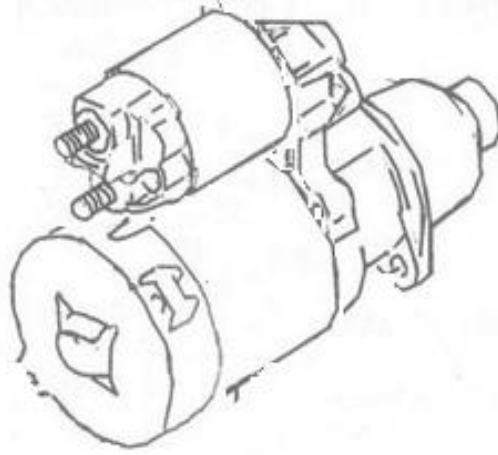

NO.	CODE NAME	Description	QTY	PT
1	3708010	STARTER	1	

CYLINDER BLOCK

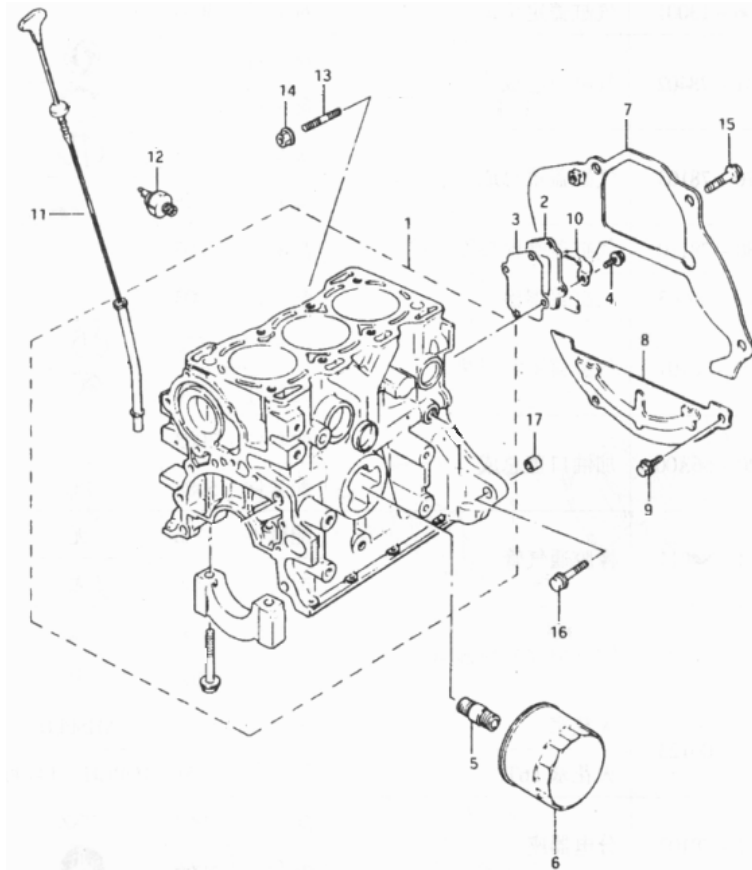

No.	Code name	Description	Qty	P/T
1	1002010	BLOCK-CYLINDER	1	
2	1002027D	PLATE-CYLINDER BLOCK	1	
3	1002028D	CASKET-PLATE	1	
4	1000096D	BOLT (M6×10)	4	
5	1012031D	STAND-OIL FILTER	1	
6	1012010D	FILTER ASSY-OIL	1	
7	1000097	PLATE-CLUTCH HOUSING UPPER	1	
8	1701149D	PLATE-CLUTCH HOUSING LOWER	1	
9	1000096D	BOLT (M6×10)	2	
10	1000026	PLANK-TIMING	1	
11	1002050	GAUGE-OIL LEVEL	1	
12	3810010D	ANNUNCIATOR-OIL PRESSURE	1	
13	1000167	STUD(M10-M10×1.25×40)	1	
14	1008036	NUT(M10×1.25)	2	
15	1000169	BOLT(M10×1.25×40)	1	
16	1000169	BOLT	1	
17	1000028D	KNOCK PIN(Φ13×16)	2	

WATER PUMP AND FAN PART

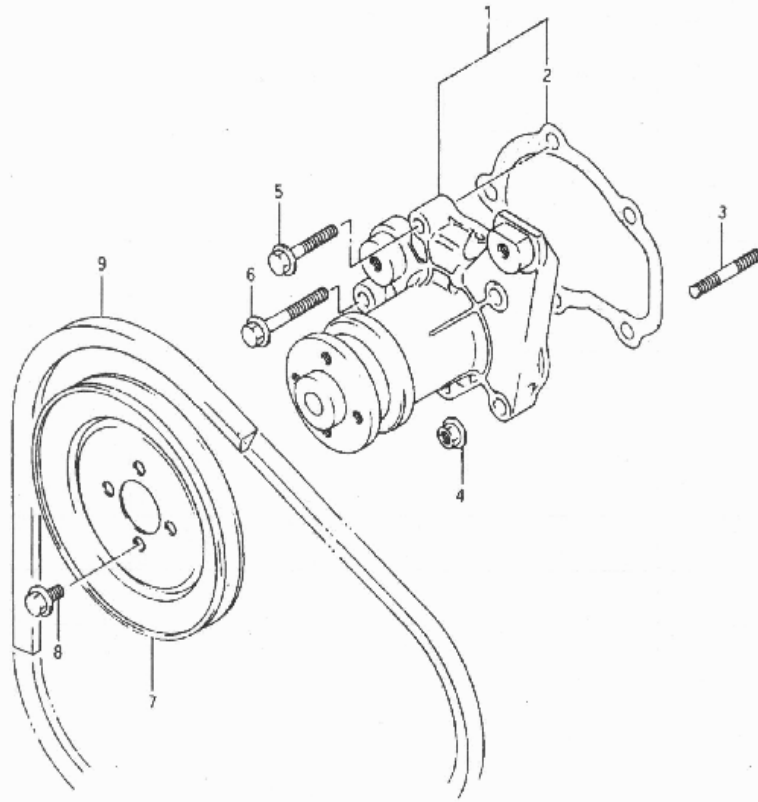

NO.	CODE NAME	Description	QTY	PT
1	1307010D	PUMP ASSY-WATER	1	
2	1000052D	GASKET-WATER PUMP	1	
3	1000092D	STUD BOLT(M6-M6x30)	2	
4	1000176	NUT	2	
5	1000083D	BOLT(M6x30)	2	
6	1000085D	BOLT (M6x40)	1	
7	1000017D	PULLET-WATER PUMP	1	
8	1000096D	BOLT(M6x10)	4	
9	1000077	BELT-WATER PUMP	1	

--	--	--	--	--

CAMSHAFT

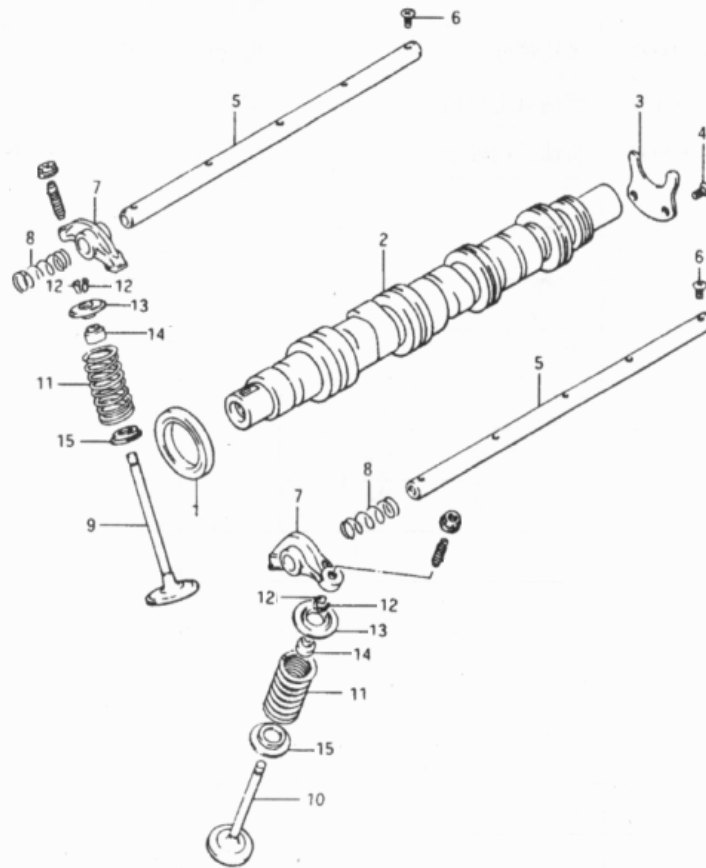

No.	Code name	Description	Qty
1	09283-32022	OIL SEAL-CAM SHAFT	1
2	1006013	CAMESHAFT	1
3	1000129D	PLATE-CAMSHAFT THRUST	1
4	GB819-1985	SCREW(M6×12)	2
5	1007045	SHAFT-ROCKER ARM	2
6	GB819-1985	SCREW(M6×16)	8
7	1007026D	ROCKER ARM-VALVE	6
8	1007035D	SPRING-ROCKER ARM	4
9	1007033D	VALVE-INLET	3
10	1007032D	VALVE-EXHAUST	3
11	1007030D	SPRING-VALVE	6
12	1007028D	COTTER-VALVE	12
13	1007029D	RETAINER-VALVE SPRING	6
14	09289-07005	OIL SEAL-VALVE	6
15	1007029D	SEAL-VALVE SPRING	6

TIMMING

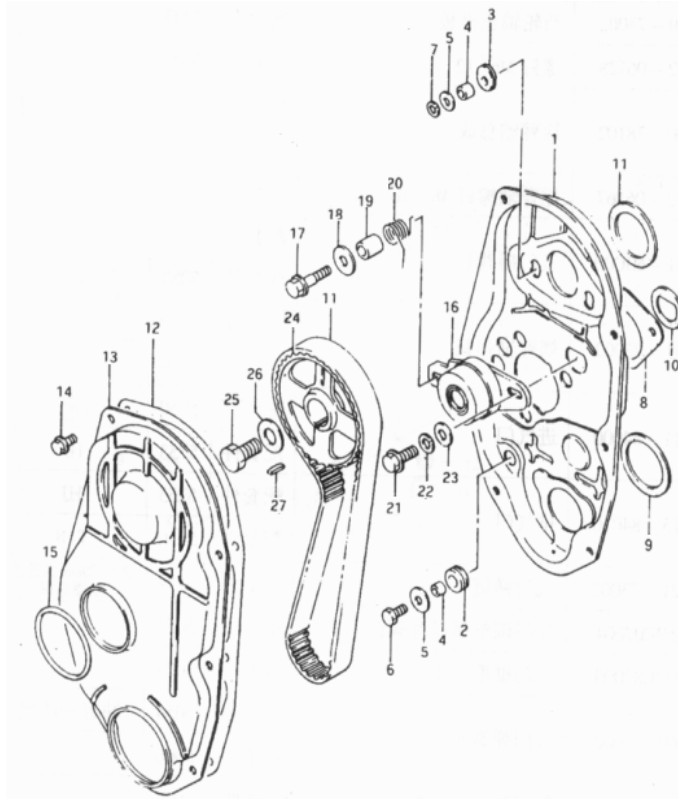

NO.	CODE NAME	Description	QTY	PT
1	1022015	COVER-INSIDE	1	
2	1022018D	GROMMET,NO1	1	
3	1022020D	GROMMET,NO2	2	
4	1022013D	BUSH(M6x10x7)	4	
5	GB96-1995	WASHER (M6.5x18x1.6)	4	
6	GB5783-1986	BOLT(M6x20)	4	
7	1000019D	WASHER	1	
8	1022019D	CUSHION SEAL	1	
9	1022012D	CUSHION SEAL	2	
10	1022014D	CUSHION SEAL	2	
11	1000053	BELT-TIMING	1	
12	1000029D	GASKET-COVER	1	
13	1023011D	COVER-OUTSIDE	1	
14	1000096D	BOLT(M6x10)	6	
15	1023013D	GROMMET-OUTSIDE	1	
16	1021010D	TENSIONER-TIMING BELT	1	

Frame

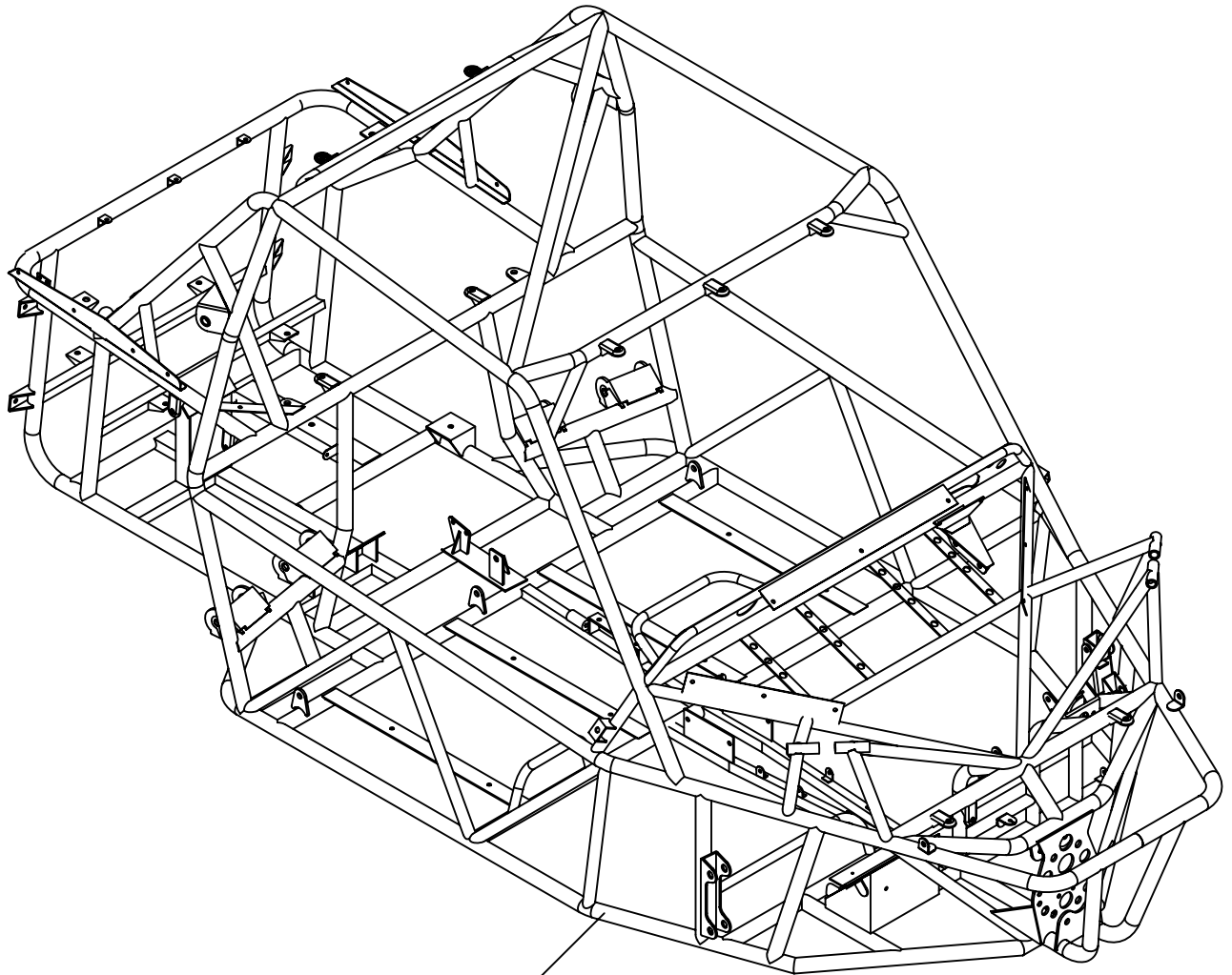

1

No.	Code name	Description	Q' ty
1	D800.01.01.00.00	Frame component	1

Engine mount assy

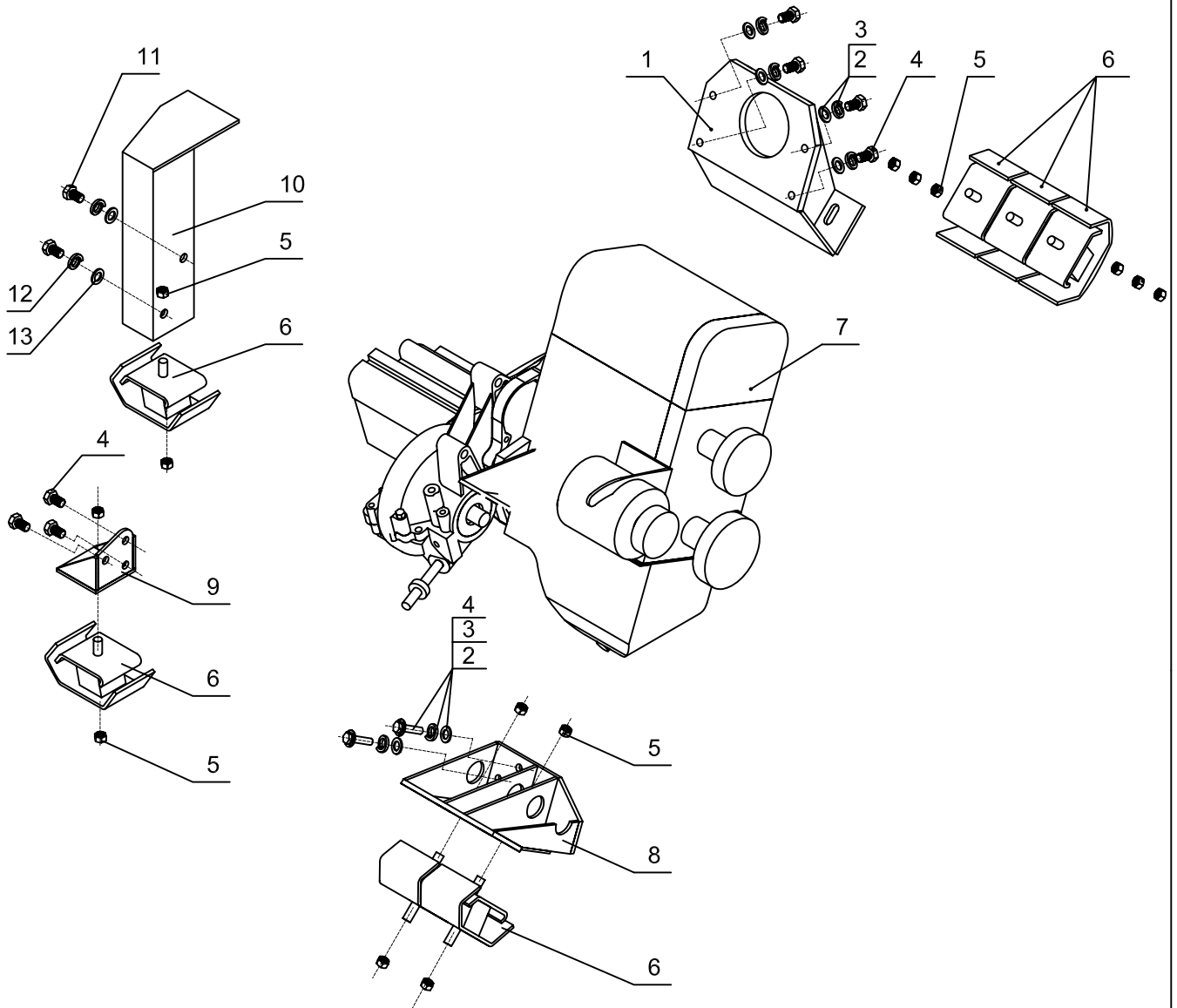

No.	Code name	Description	Q' ty
1	D800.04.01.01.00	front engine mount	1
2	GB/T95 standard	washer Ø8	11
3	GB/T93-1987	spring shim Ø8	11
4	GB/T5787-1986	bolt-washer M8*20	11
5	GB/T6177.1-2000	nut M10*1.25	14
6	D650.04.01.00.01	engine rubber bumper	7
7	D800.04.01.04.00	372 engine	1
8	D800.04.01.02.00	rear engine mount	1
9	D800.04.01.03.00	transmission mount	1
10	D650.04.01.03.00	left engine mount	1
11	GB/T5787-1986	bolt-washer M10*1.25*20	2
12	GB/T93-1987	spring shim Ø10	2
13	GB/T95 standard	washer Ø10	2

Gear-shift mechanism

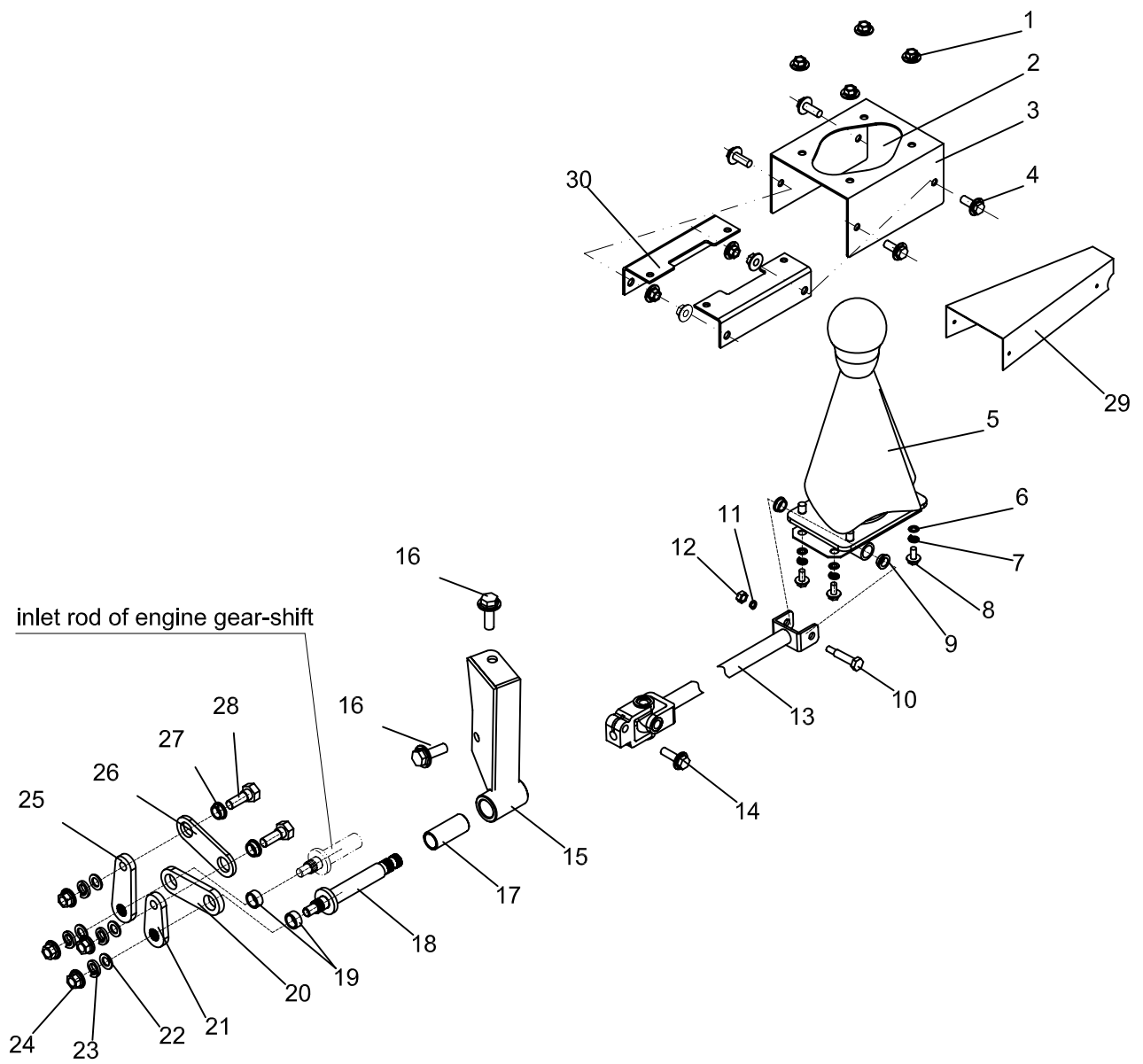

No.	Code name	Description	Q' ty
1	GB/T6177.1-2000	M8 caulking nut	4
2	GB/T6177.1-2000	M8 caulking nut	4
3	D650.05.02.02.03	shifter mount	1
4	GB/T5787-86	M8*20 bolt	4
5	D650.05.02.02.04	shifter assembly	1
6	GB/T95 standard	Ø6 washer(Ø6.6*Ø12*1.6)	4
7	GB/T 93-1987	Ø6 spring shim	4
8	GB/T5787-86	M6*15 bolt	4
9	D650.05.02.02.02	bush of gear shift hand grip	2
10	D650.05.02.02.01	axle bolt	1
11	GB/T 93-1987	Ø6 spring shim	2
12	GB/T 6170-2000	M6 nut(m=5.2)	1
13	D800.05.02.00.01	gear shift lever	1
14	GB5787-86	M8*35 bolt	1

Gear-shift mechanism

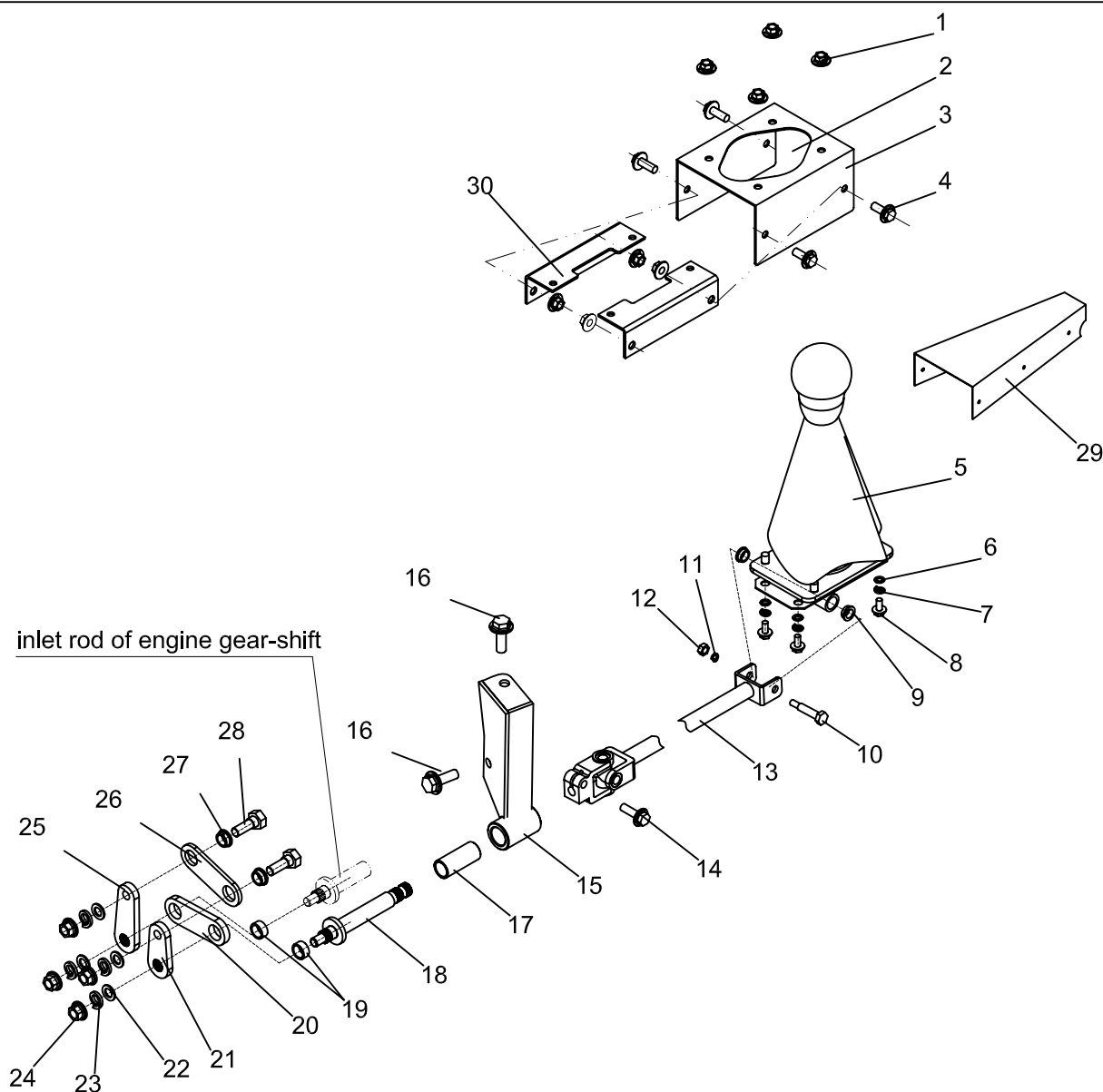

No.	Code name	Description	Q' ty
15	D650.05.02.04.00	guide holder	1
16	GB5787-86	M8*1.25*20 bolt	2
17	JD0580002	nylon bush	1
18	D650.05.02.01.01	shift shaft	1
19	D650.05.02.02.02	copper sheathing	2
20	D650.05.02.02.03	rack	1
21	D650.05.02.02.05	short crank	1
22	GB/T95 standard	Ø10 washer(Ø10.5*Ø18*1.6)	2
23	GB/T 93-1987	Ø10 spring shim	2
24	GB/T6177.1-2000	M10*1.25 nut	2
25	D650.05.02.01.04	rocking bar	1
26	D650.05.02.01.06	connecting bar	1
27	D650.05.02.01.08	flange copper sheathing	2
28	D650.05.02.01.07	axle bolt	2
29	D800.01.02.00.03	cover	1
30	D800.01.02.00.04	bracket	2

Steering assy

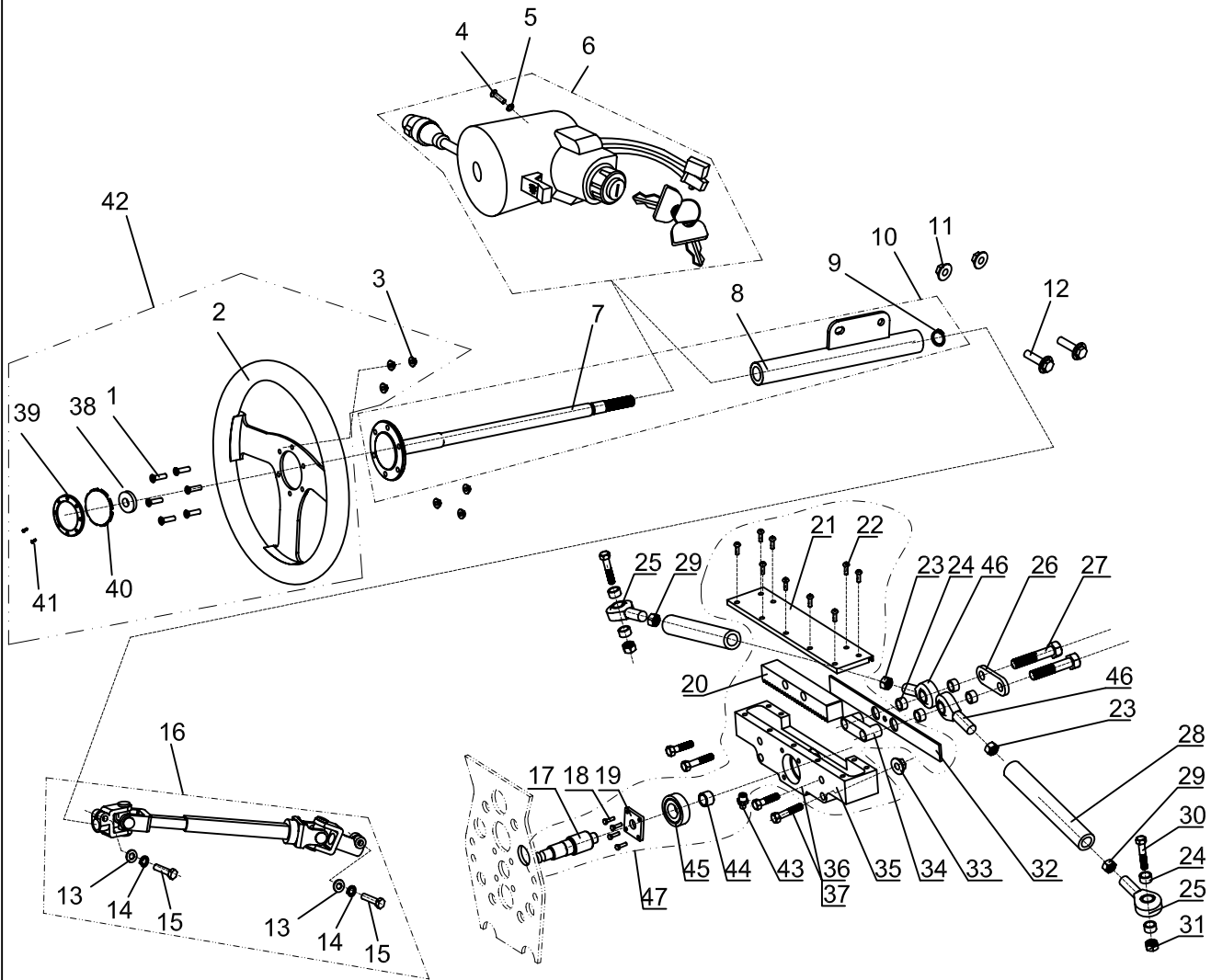

No.	Code name	Description	Q' ty
1	GB/T818-2000	M6*20 screw	6
2	DI250.03.01.00.03	steering wheel	1
3	GB6177.1-2000	M6 caulking nut	6
4	GB/T 819.1-2000	bolt M6*10	1
5	GB/T6172.1-2000	Ø6 spring shim	1
6	D650.04.04.00.04	integrated switch assembly	1
7	D800.05.01.01.01	steering wheel shaft	1
8	D800.05.01.01.02	steering column housing	1
9	GB/T894.1-1986	Ø15 external circlip	1
10	D800.05.01.01.00	steering column assy	1
11	GB/T6177.1-2000	M10*1.25 nut	2
12	GB5787-1986	M10*1.25*25 bolt	2
13	GB/T96 big	Ø8 washer(8.4*24*2)	2
14	GB/T 93-1987	Ø8 spring shim	2
15	GB/T5782-2000	M8*25 bolt	2
16	D800.05.01.02.00	steering universal rod	1
17	D800.05.01.03.02	steering gear shaft	1
18	GB/T5787-1986	M8*20 bolt	4

Steering assy

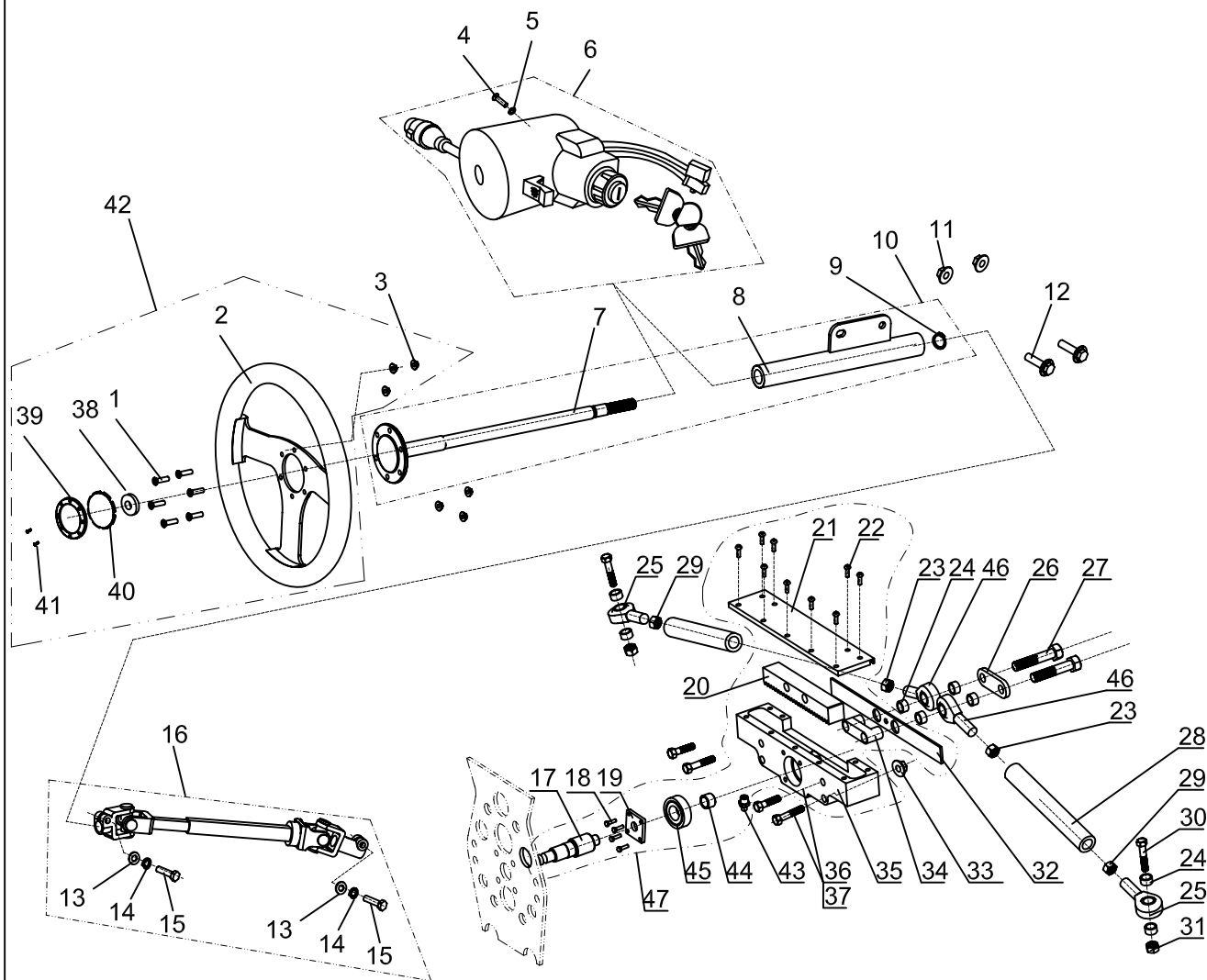

No.	Code name	Description	Q' ty
19	D800.05.01.03.05	bearing cover	1
20	D800.05.01.03.04	gear rack	1
21	D800.05.01.03.03	capping plate	1
22	GB/T2672—1986	socket head screw M6*12	9
23	GB6172.1-2000	jam nut M12*1.75	2
24	D800.05.01.00.03	spacer sleeve	4
25	D800.05.01.00.01	rod end bearingPOSA12LH	2
26	D800.05.01.00.04	baffle plate	1
27	GB/T5782-2000	M12*1.25*80 bolt	2
28	D800.05.01.04.00	steering cross rod	2
29	GB6172.1-2000	jam nut M12*1.75LH	2
30	GB/T5787-1986	M12*1.5*60 bolt	2
31	GB6177.1-2000	M12x1.5 nut	2
32	D800.05.01.03.07	dust guard plate	1
33	GB6177.1-2000	M10*1.25 nut	2
34	D800.05.01.03.06	bracket	1

Steering assy

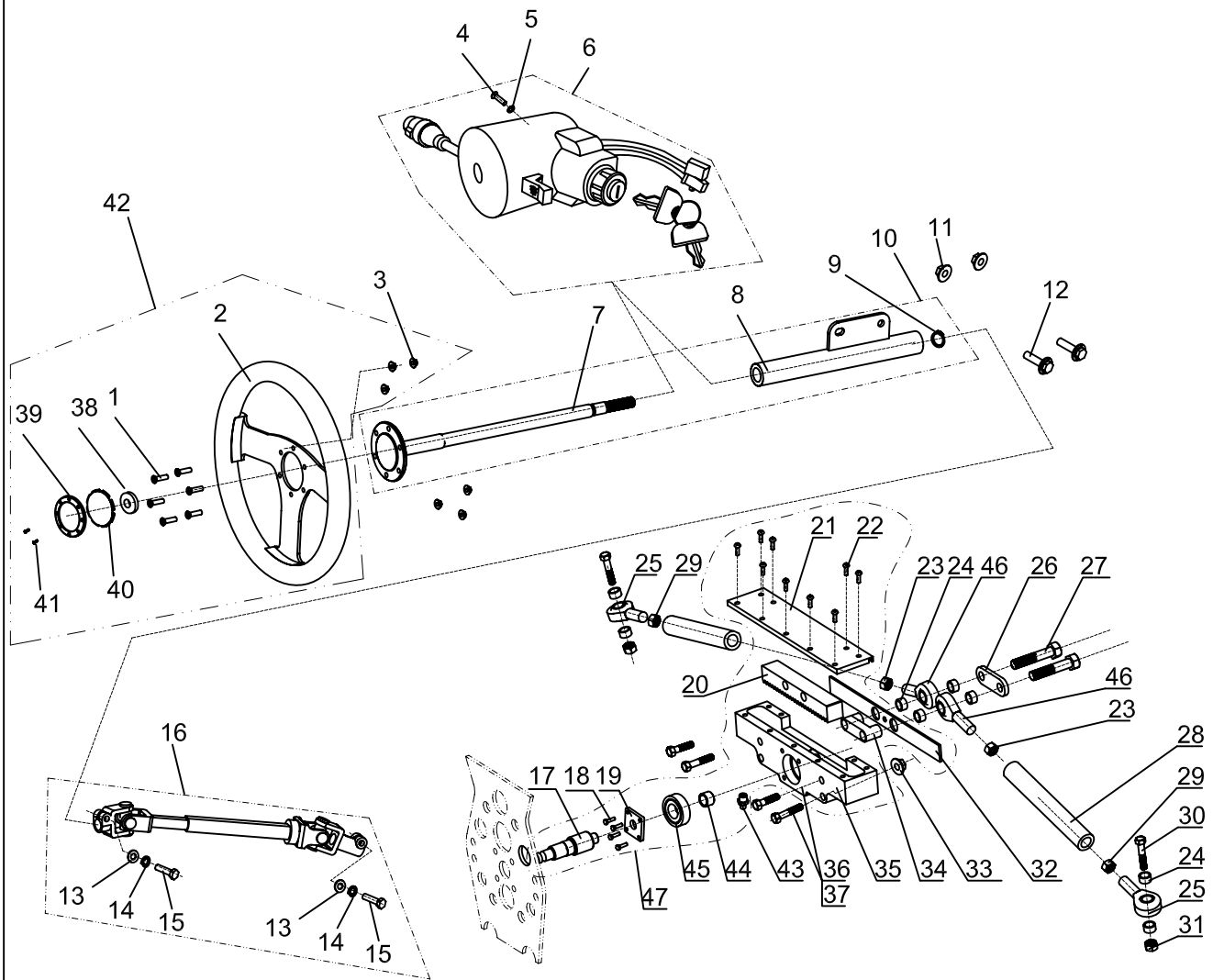

No.	Code name	Description	Q' ty
35	D800.05.01.03.01	socket	1
36	GB/T5787-1986	bolt M10*1.5*10	2
37	GB/T5787-1986	bolt M10*1.25*75	2
38	DI250.03.00.00.02	rubber block	1
39	DI250.03.01.00.01	plastic cover	1
40	DI250.03.01.00.02	rubber cover	1
41	GB70-85	bolt M4*16	2
42	DI250.03.01.00.00	steering wheel subassembly	1
43	D800.05.01.03.08	adding oil mouth	1
44	D800.05.01.03.10	oiliness bearing 14c7*18*12	1
45	D800.05.01.03.09	ball bearing 20*42*12	1
46	D800.05.01.00.02	rod end bearingPOSA12	2
47	D800.05.01.03.00	steering gear box	1

Throttle and park assy

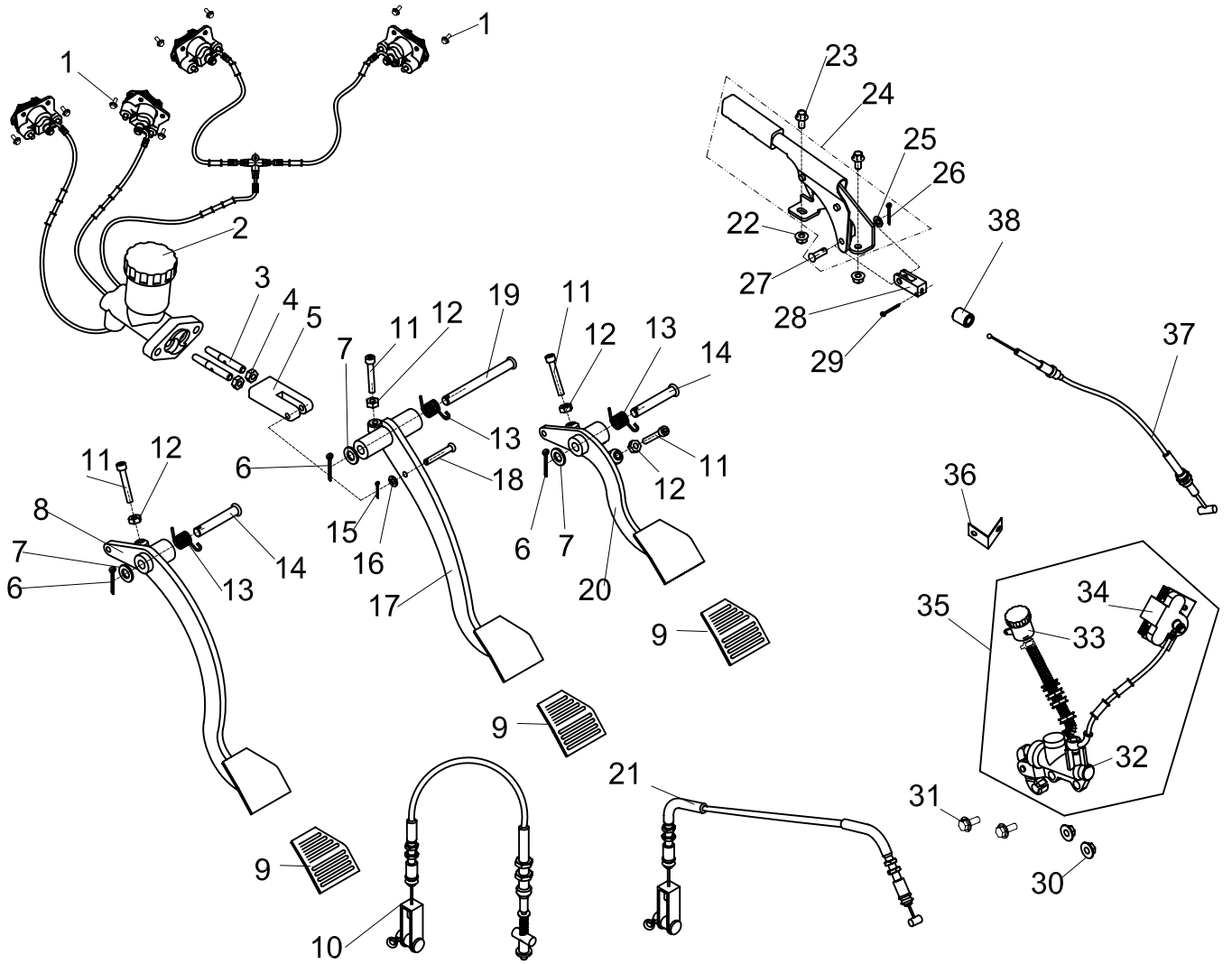

No.	Code name	Description	Q' ty
1	GB/T5787-86	M8*20 bolt	8
2	D800.07.01.01.00	four-calliper brake assy	1
3	D650.07.01.00.04	pushing bar	2
4	GB/T6172.1-2000	M8 nut	2
5	D650.07.01.00.03	push rod holder	1
6	GB/T91-2000	cotter pin 3.2*30	3
7	GB/T 95 standard	Ø10 washer(Ø10.5*Ø18*Ø1.6)	3
8	D800.07.04.02.00	clutch pedal	1
9	D650.07.01.00.05	pedal rubber cover	3
10	D650.07.04.01.00	cable, clutch	1
11	GB/T 70.1-2000	M6*55 socket head bolt	4
12	GB/T 6170-2000	M6 nut(m=5.2)	4
13	D250.10.003	spring	3
14	D650.07.03.00.01	Ø10*60 pin roll	2
15	GB/T 91-2000	cotter pin Ø2*25	1

Throttle and park assy

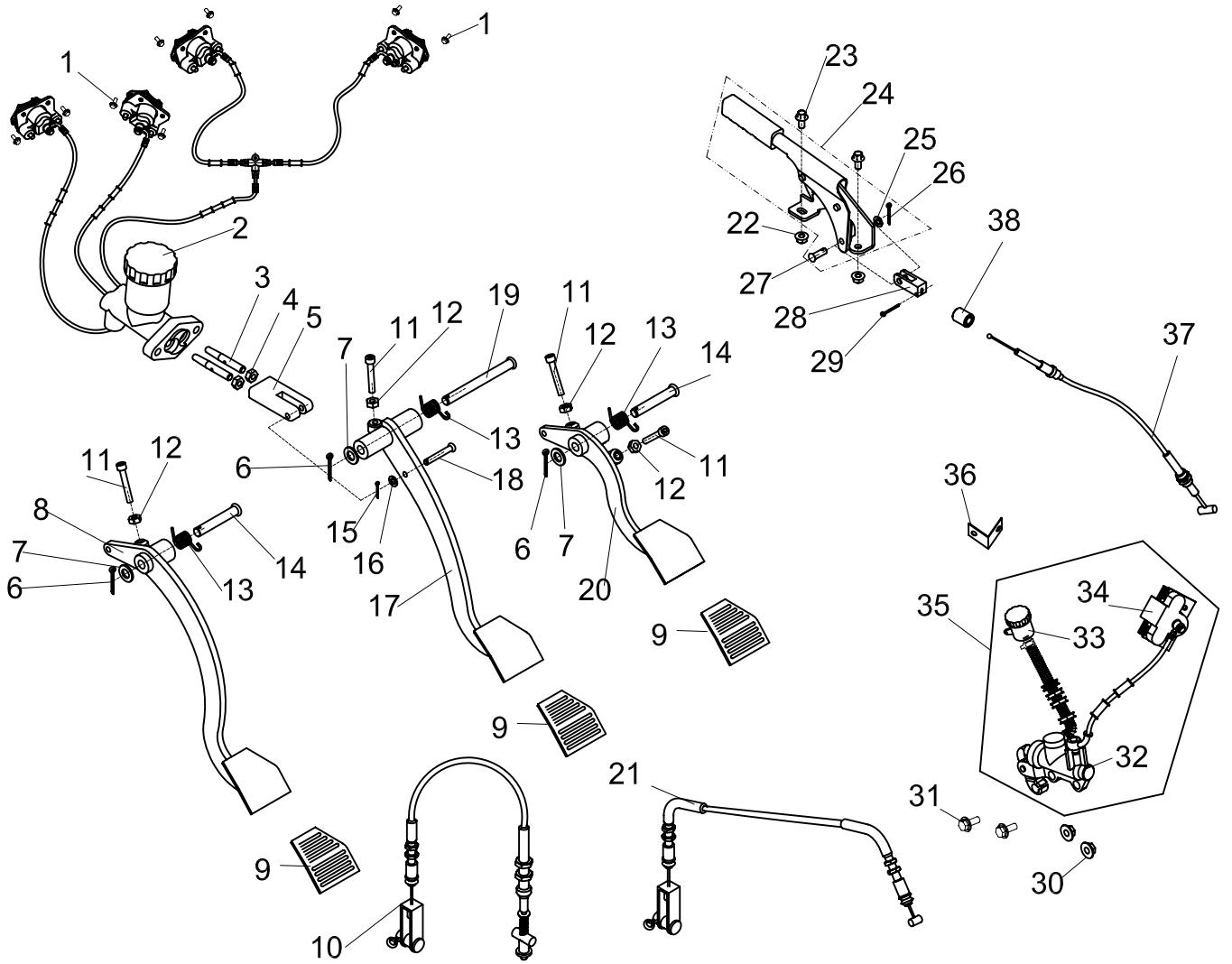

No.	Code name	Description	Q' ty
16	GB/T 95 standard	Ø6 washer	1
17	D800.07.01.02.00	brake bar	1
18	D650.07.01.00.01	Ø6*40 pin roll	1
19	D650.07.01.00.02	Ø10*105 pin roll	1
20	D800.07.03.02.00	throttle pedal	1
21	D800.07.03.01.00	cable ,throttle	1
22	GB/T6177.1-2000	M8 caulking nut	2
23	GB/T5787-86	M8*20 bolt	2
24	D650.07.02.01.00	park assy	1
25	GB/T848 small	Ø8 washer	1
26	GB/T91-2000	cotter pin 3.2*30	1
27	D650.07.02.01.01	axle 8*24	1
28	D650.07.02.00.01	connection , parking brake	1
29	GB/T91-2000	cotter pin 3.2*30	1
30	D650.07.02.02.00	M8 caulking nut	2

Throttle and park assy

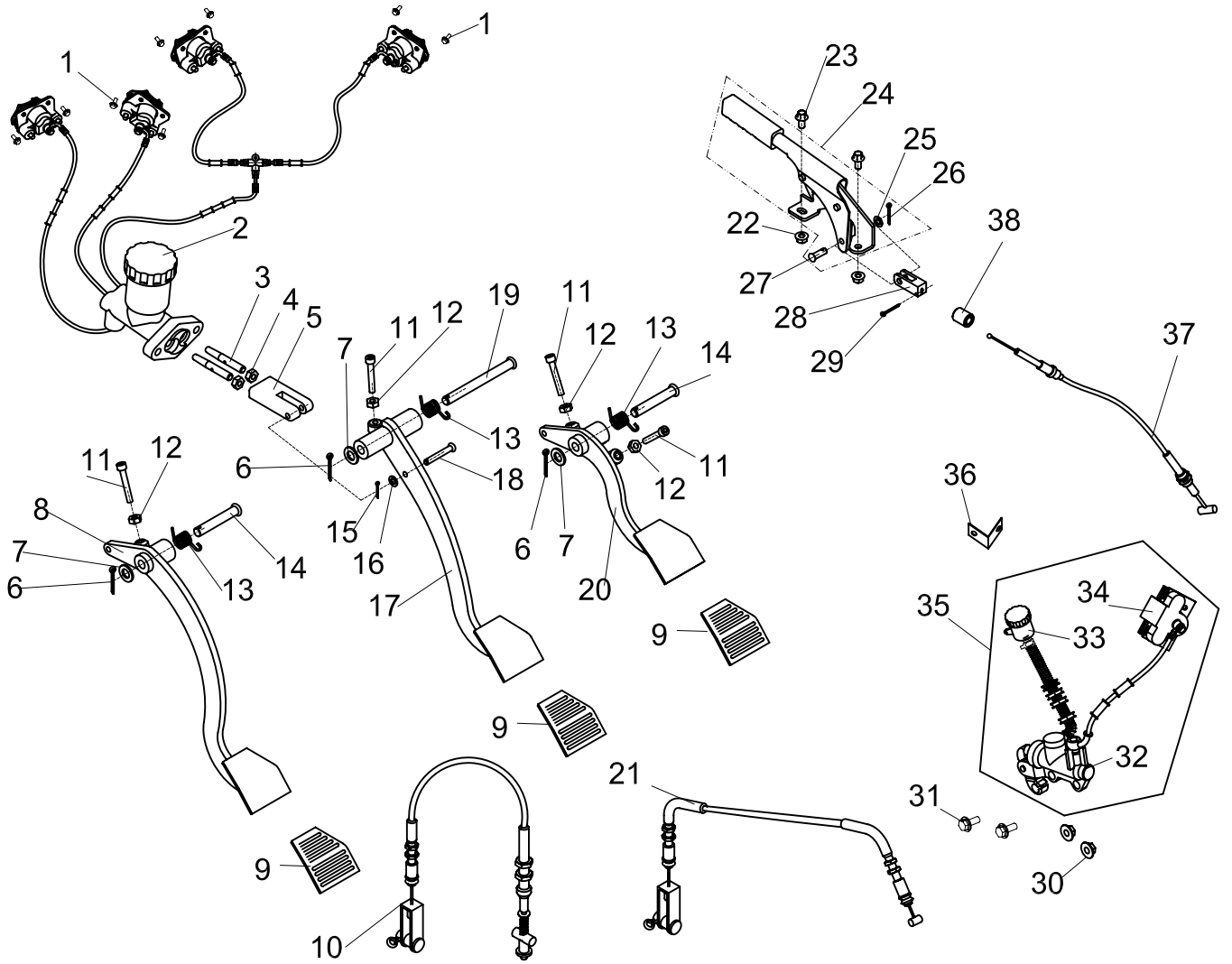

No.	Code name	Description	Q' ty
31	D650.07.02.00.02	bolt-washer M8*30	2
32	D650.07.02.03.00	pump single hydraulic assy	1
33	D650.07.02.03.02	oil cup single hydraulic assy	1
34	D650.07.02.03.03	caliper single hydraulic assy	1
35	D800.07.02.03.00	single hydraulic park brake assy	1
36	D650.07.02.00.03	oil cup brasket	1
37	D650.07.02.00.20	park brake cable	1
38	D800.07.02.00.01	steel bush	1

Front susp assy

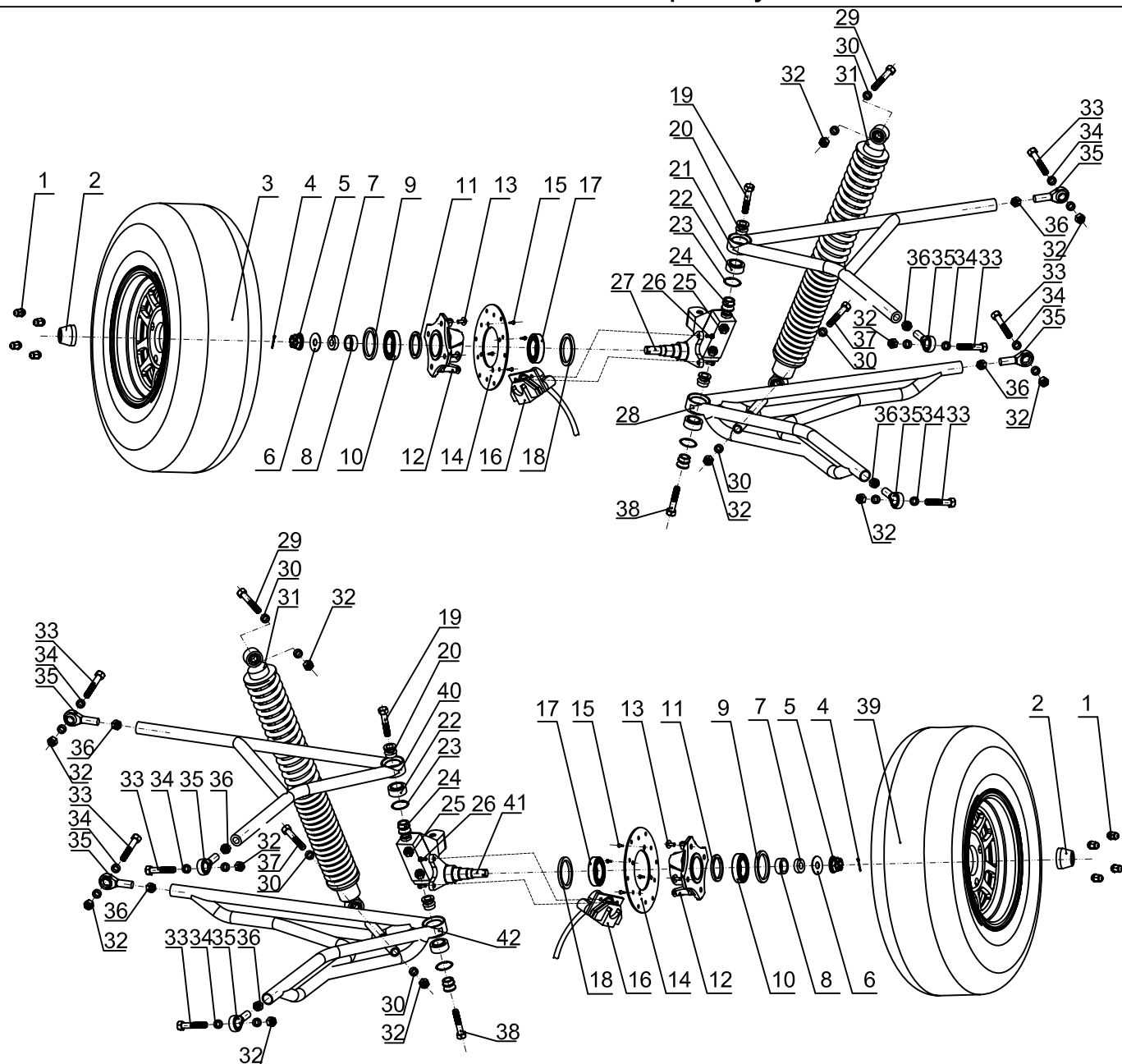

No.	Code name	Description	Q' ty
1	D650.03.02.00.03	M10*1.25 wheel nut	8
2	JD0360010	rubber dirt-proof boot	2
3	D800.03.01.01.00	left wheel(25*8-12)	1
4	GB/T 91-2000	cotter pin	2
5	GB/T9457-1988	slotted nut	2
6	D800.03.01.00.10	washer	2
7	D650.03.01.00.08	spacer sleeve	2
8	D800.03.01.00.07	axile bush	2
9	D800.03.01.00.08	30*52*8 grease seal	2
10	D800.03.01.00.04	ball bearing 25X52X15	2
11	D800.03.01.00.06	spacer sleeve	2
12	D800.03.01.00.01	front hub	2
13	D650.03.02.00.03	knurled screw M10*1.25	8
14	D650.03.02.00.05	brake disk	2
15	D650.03.02.00.08	M6 bolt	8

Front susp assy

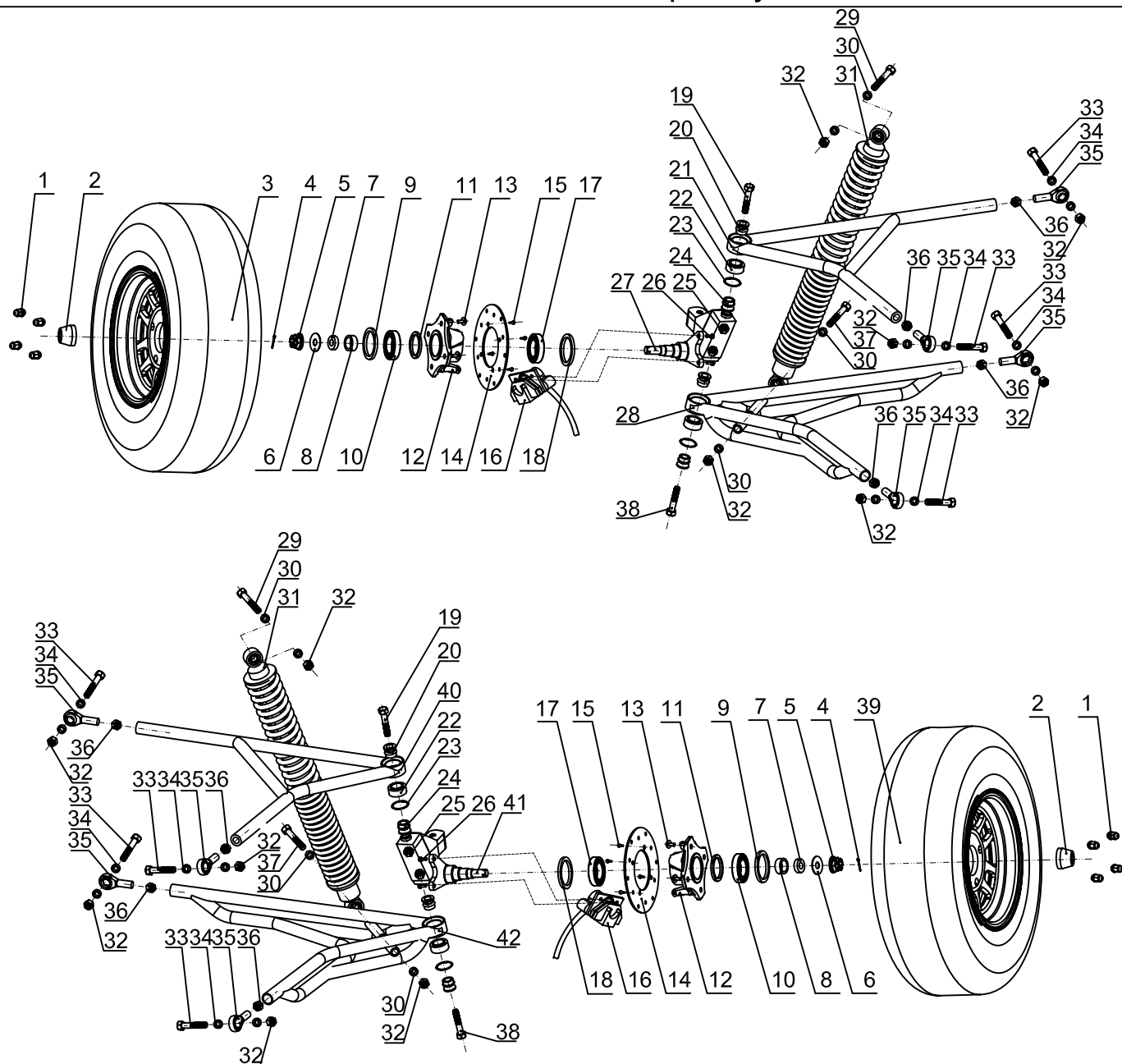

No.	Code name	Description	Q' ty
16	D800.07.01.01.00	four-calliper brake assy	1
17	D800.03.01.00.05	30*62*16 ball bearing	2
18	D800.03.01.00.09	40x62x7 grease seal	2
19	GB/T5782-2000	M16*2*85 bolt	2
20	D800.02.01.00.02	bushing	8
21	D800.02.01.02.00	upper control arm,left	1
22	D800.02.01.00.01	radial bearing	4
23	GB/T 893.2	circlip	4
24	D800.02.01.00.02	bushing	8
25	GB/T6185.1-2000	M16*2 nut	4
26	GB/T5787-1986	M8*20 bolt	4
27	D800.03.01.00.02	left wheel axle,front	1
28	D800.02.01.01.00	lower control arm,right	1
29	GB/T5782-2000	M15*1.5*190 bolt	2
30	D800.02.03.00.03	spacer sleeve,shocker	8

Front susp assy

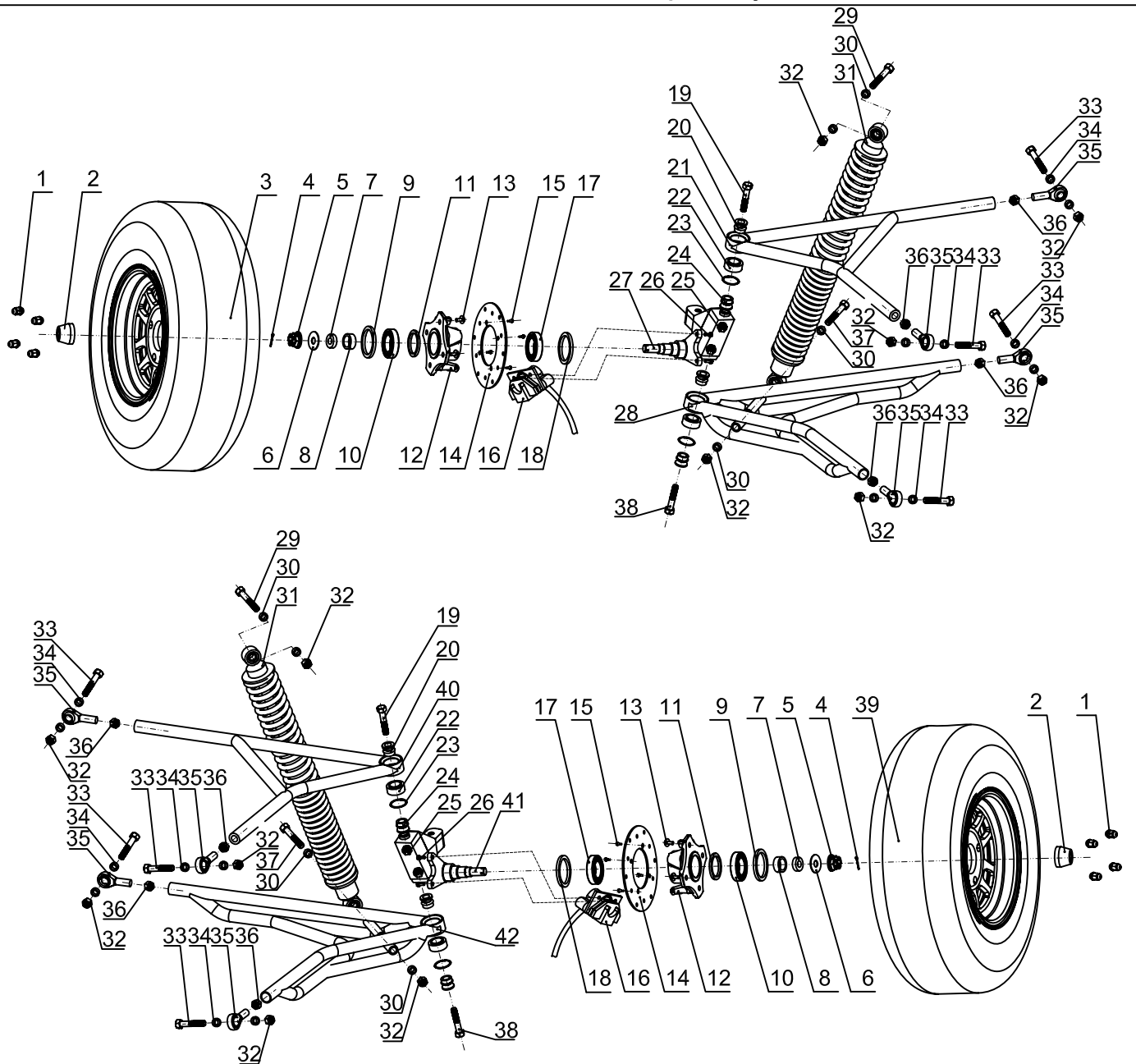

No.	Code name	Description	Q' ty
31	D800.02.03.01.00	front shocker	2
32	GB/T6185.1-2000	M15*1.5 nut	2
33	GB/T5782-2000	M16*2*65 bolt	8
34	D800.02.01.00.04	spacer sleeve, control arm	16
35	D800.02.01.00.03	rod end bearing, control arm	4
36	GB/T6172.2-2000	jam nut M16*2	8
37	GB/T5782-2000	M15*1.5*210 bolt	2
38	GB/T5782-2000	bolt M16*2*95	2
39	D650.03.01.02.00	right wheel(25*8-12)	1
40	D800.02.01.03.00	right upper control arm	1
41	D800.03.01.00.03	right wheel axle, front	1
42	D800.02.01.04.00	right lower control arm	1

Fuel tank and gasoline pump

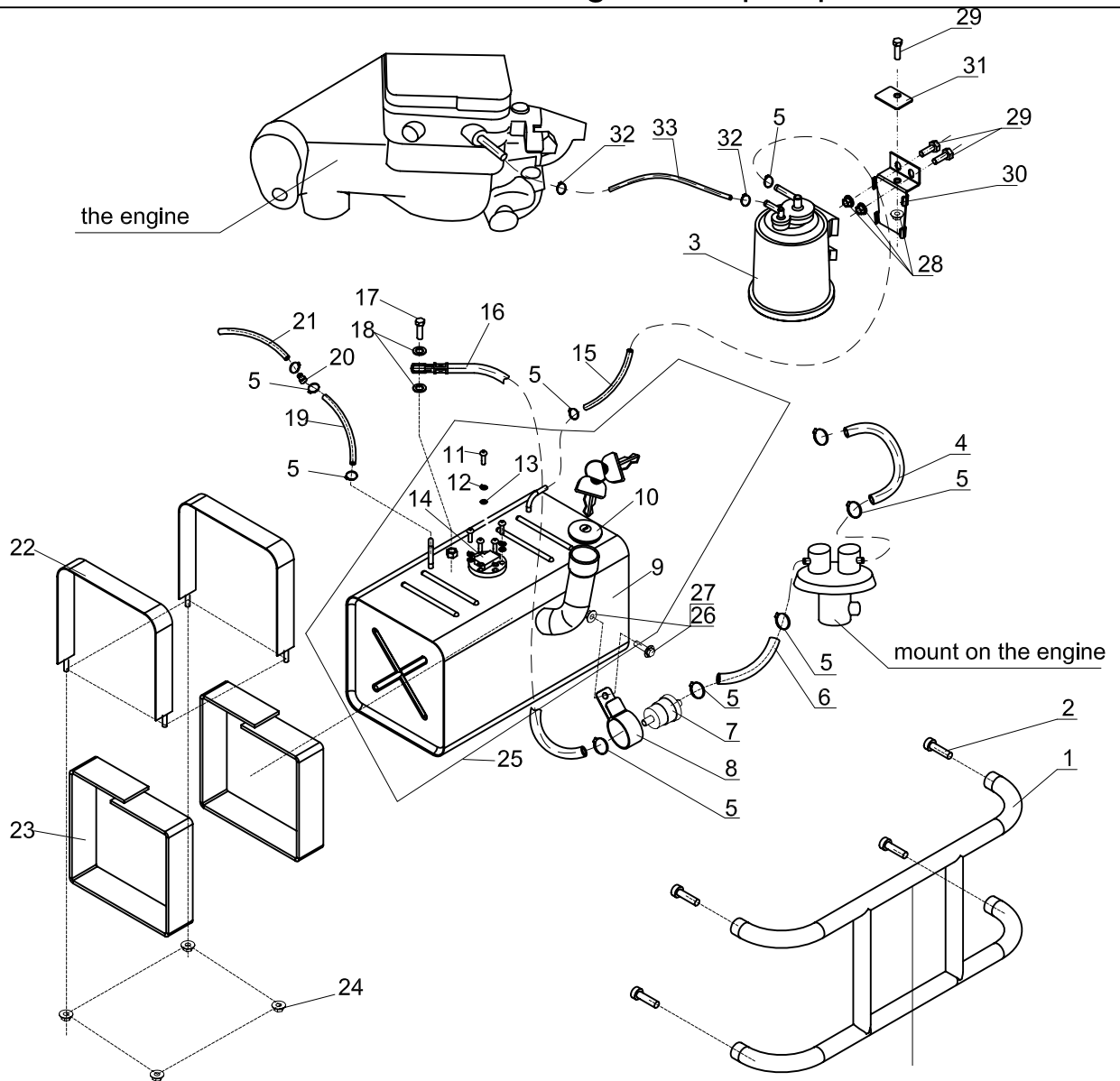

No.	Code name	Description	Q' ty
1	D800.01.02.03.00	fender bracket , fuel tank	1
2	GB/T70.1-2000	M12*30 socket head screw	4
3	D650.04.06.01.00	fuel collector	1
4	D650.04.03.00.07	outlet tube,fuel pump	1
5	D650.04.03.00.04	anchor ear	7
6	D650.04.03.00.11	inlet tube,fuel pump	1
7	D650.04.03.00.05	gasoline filter	1
8	D650.04.03.00.10	anchor ear of gasoline filter	1
9	D800.04.03.01.00	fuel tank	1
10	D650.04.03.01.03	fuel tank cap	1
11	GB/T818-2000	bolt-cross M5*12	5
12	GB/T93-1987	Ø5 spring shim	5
13	GB/T95-1985	Ø5 washer	5
14	D650.04.03.01.02	oil-depth gauge	1
15	D650.04.03.00.01	vent pipe	1
16	D650.04.03.03.00	outlet tube,fuel tank	1
17	D650.04.03.00.02	hollow screw	1

Fuel tank and gasoline pump

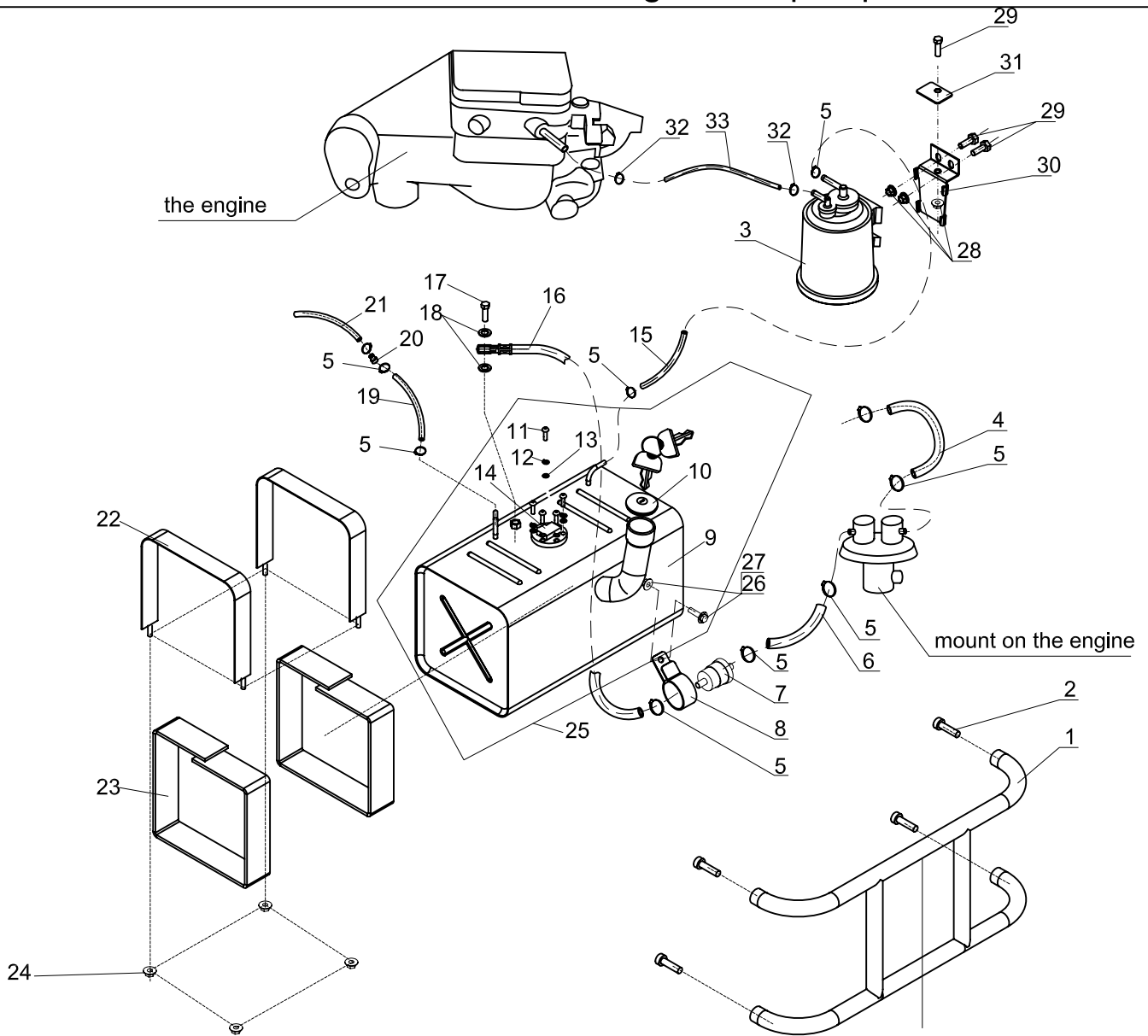

No.	Code name	Description	Q' ty
18	D650.04.03.00.08	copper washer	2
19	D650.04.03.00.03	heavy calibre return tube,fuel tank	1
20	D800.04.03.00.01	patchplug	1
21		minor-caliber return tube,fuel tank	1
22	D800.04.03.02.00	fuel tank strap	2
23	D800.04.03.00.03	fuel tank rubber strap	2
24	GB6177.1-2000	M10 nut	4
25		fuel tank assembly	1
26	GB/T5787-1986	M8*25 bolt	1
27	GB/T6177.1-2000	M8 nut	1
28	GB/T5787-1986	M6 nut	3
29	GB/T6177.1-2000	M6*16 bolt	3
30	D650.04.06.01.01	mount	1
31	D650.04.06.01.02	sheet metal	1
32		hoop	2
33		M8 nut	1

spot lights and radiator assy

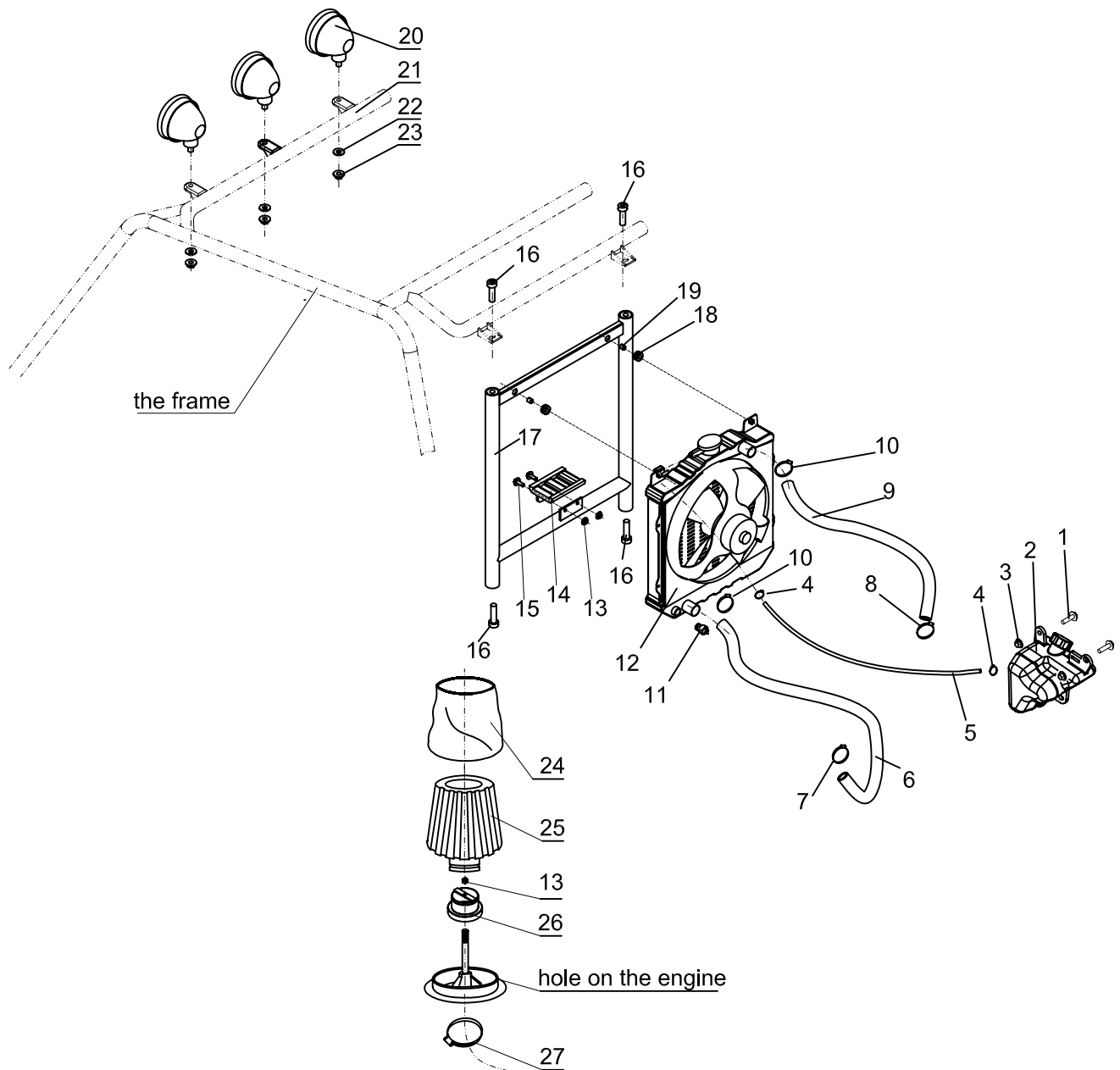

No.	Code name	Description	Q' ty
1	GB/T5787-1986	bolt-washer M8*20	2
2	D25009903	overflow bottle	1
3	GB/T6177.1-2000	caulking nut M8	2
4	D650.04.03.00.04	hoop(10-16)	2
5	D650.04.02.00.04	overflow bottle hose	1
6	D650.04.02.00.02	water outlet hose , engine	1
7	D650.04.02.00.03	hoop(25-38),water tube	1
8	D650.04.02.00.03	hoop(25-38),water tube	1
9	D650.04.02.00.01	water inlet hose, engine	1
10	D650.04.02.00.03	hoop(25-38),water tube	2
11	D650.04.02.03.00	temperature detect switch(TDS)	1
12	D800.04.02.01.00	radiator assembly	1
13	GB/T6177.1-2000	M6 caulking nut	3
14	D800.01.02.05.00	radiator lower mount	1
15	GB/T5787-86	bolt-washer M6*15	2

spot lights and radiator assy

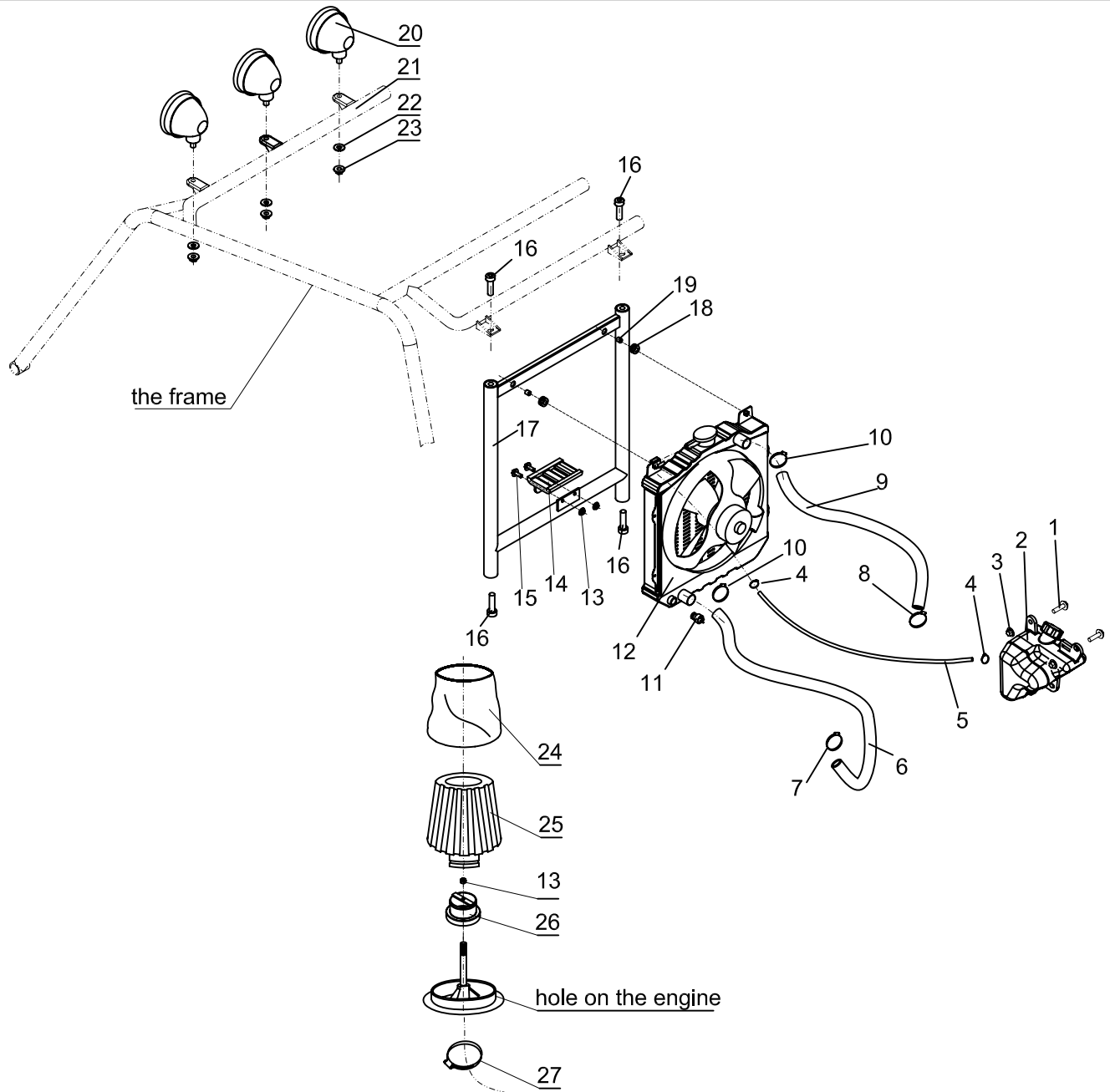

No.	Code name	Description	Q' ty
16	GB/T70.1-2000	M12*1.5*30 socket head bolt	4
17	D650.01.02.05.00	radiator mounting bar	1
18	JD1910003	radiator rubber washer	2
19	JD1910002	spacer sleeve,radiator assy	2
20	D650.06.00.12.00	spot lights	3
21	D800.01.01.00.00	frame	1
22	GB/T93-1987	spring washer Ø12	3
23	GB/T6177.1-2000	M12 nut	3
24	D800.08.01.00.04	dirt-proof boot	1
25	D800.04.05.01.00	air filter	1
26	D800.04.05.02.00	collar	1
27	D800.04.05.00.01	anchor ear	1

Shooting lights and radiator assy

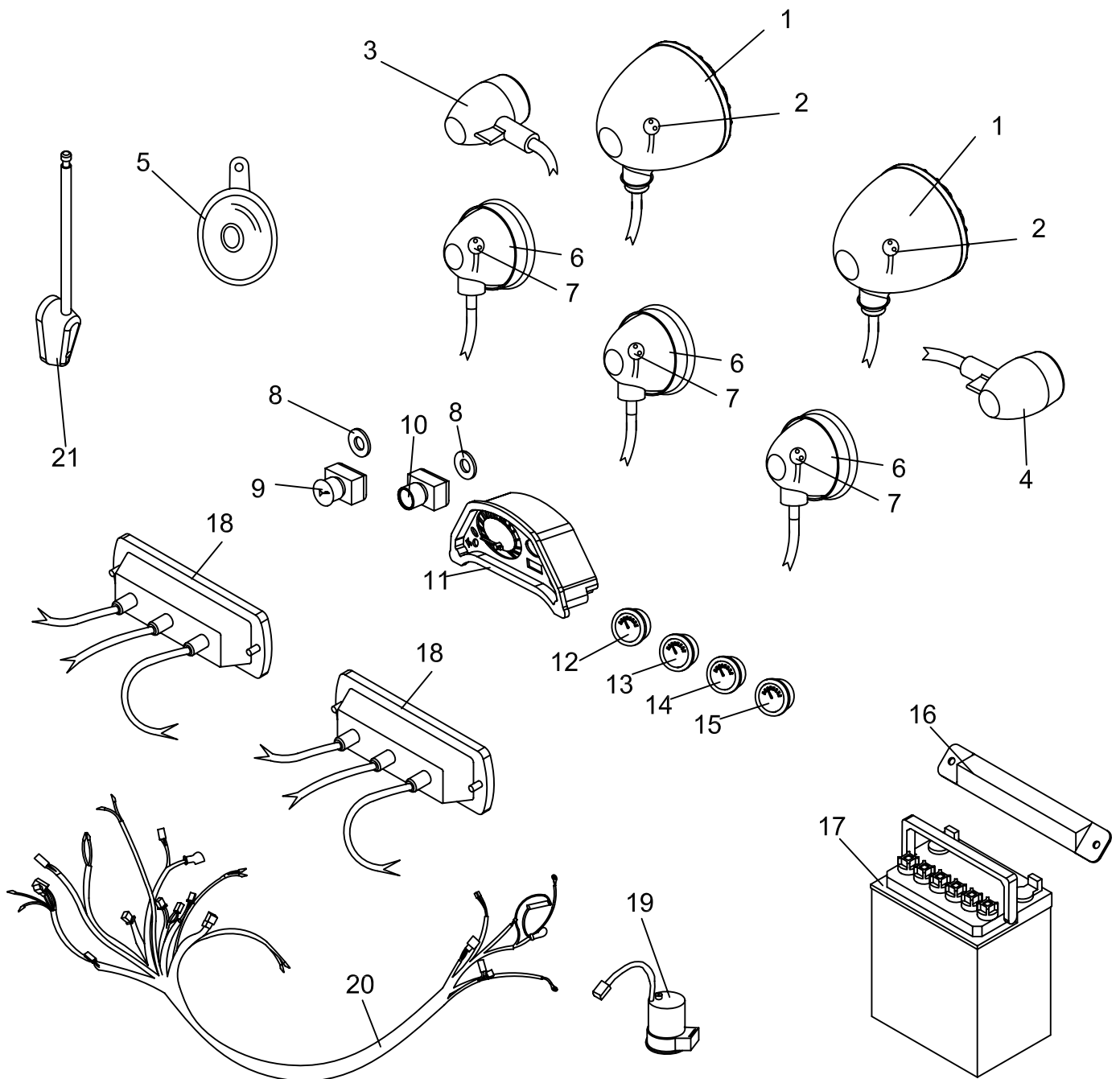

No.	Code name	Description	Q' ty
1	D650.06.00.03.00	headlight	2
2	D650.06.00.03.01	bulb of headlight	2
3	D650.06.00.05.00	left turn light,front	1
4	D650.06.00.15.00	right turn light,front	1
5	D650.06.00.09.00	horn	1
6	D650.06.00.12.00	spot light	3
7	D650.06.00.12.01	bulb of spot light	3
8	JD0460003	washer	2
9	D650.06.00.13.00	horn button	1
10	D650.06.00.14.00	spot light button	1
11	D650.06.00.07.00	instrument cluster	1
12	D800.06.00.00.02	speed indicator	1

Shooting lights and radiator assy

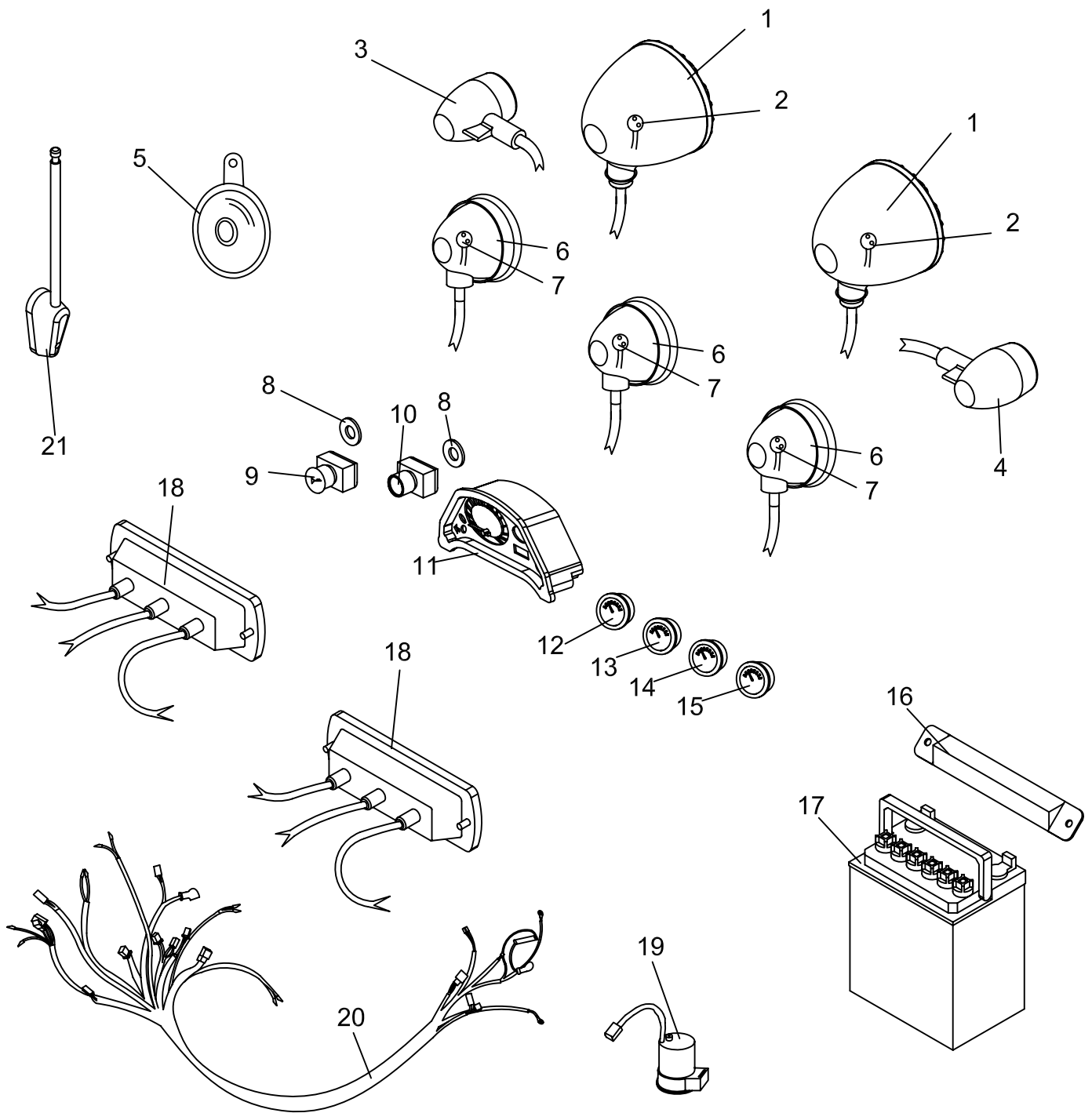

No.	Code name	Description	Q' ty
13	D800.06.00.00.03	water temperature indicator	1
14	D800.06.00.00.04	volt meter	1
15	D800.06.00.00.05	fuel quantity meter	1
16	D650.01.02.08.00	battery bracket	1
17	D650.08.01.00.01	battery	1
18	D800.06.00.00.12	rear lamp assembled	2
19	D650.06.00.04.00	flash apparatus	1
20	D800.06.00.00.01	electric cable	1
21	D800.06.00.00.11	antenna	1
22			1

muffle assy

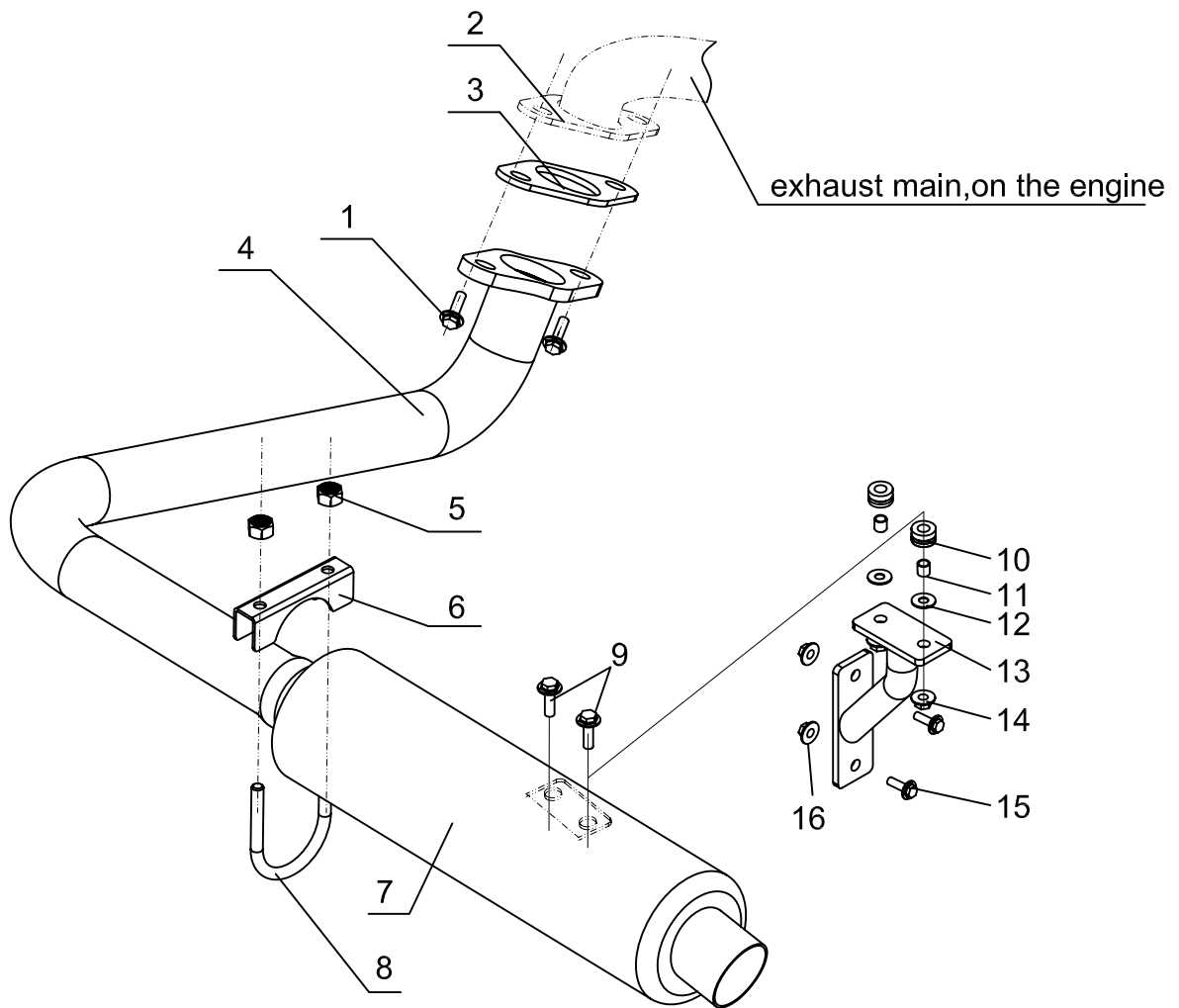

No.	Code name	Description	Q' ty
1	GB/T5787-86	bolt-washer M10*1.25*40*25	2
2		exhaust main,on the engine	1
3	D650.04.04.00.01	flange gasket	1
4	D800.04.04.01.01	winding pipe	1
5	GB/T6177.1-2000	caulking nut M8	2
6	D650.04.04.00.08	anchor ear	1
7	D650.04.04.01.00A	muller	1
8	D650.04.04.00.08	anchor ear	1
9	GB/T5787-1986	bolt-washer M8*30	2
10	JD1910002A	rubber blanket	2
11	JD1910002	spacer sleeve	2
12	GB/T96 big	washer Ø8*24*2	2
13	D800.04.04.02.00	muller bracket	1
14	GB/T6177.1-2000	M8 caulking nut	2
15	GB/T5787-1986	bolt-washer M10*1.25*25	2
16	GB/T6177.1-2000	nut M10*1.25	2

seat and safety belt

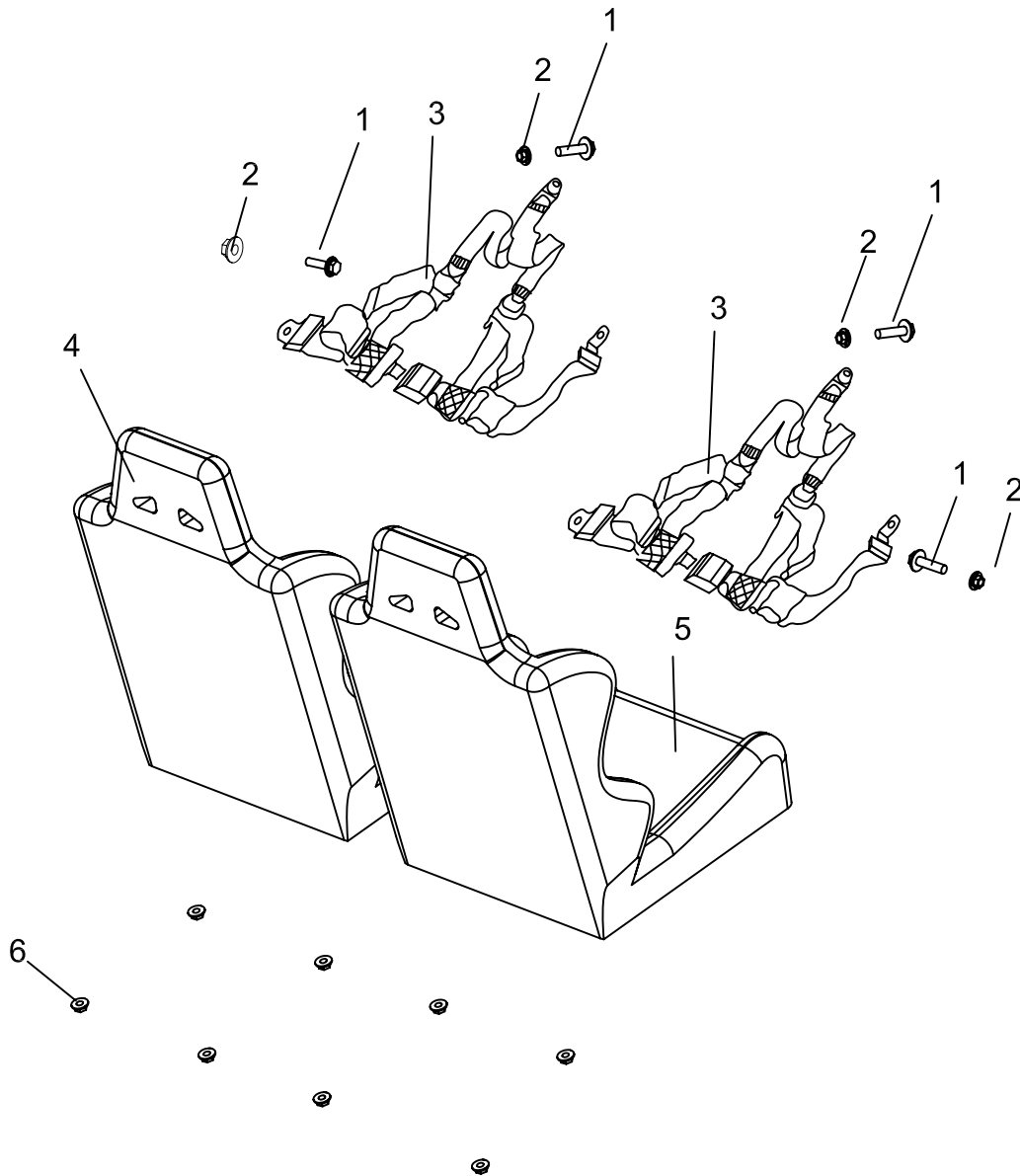

No.	Code name	Description	Q' ty
1	GB/T5787-86	bolt M12*1.5*25	6
2	GB/T6177.1-2000	nut M12*1.5	6
3	D650.08.01.00.01	safty belt	2
4	D800.08.01.01.00	seat , left	1
5	D800.08.01.01.00	seat , right	1
6	GB/T6177.1-2000	nut M10*1.25	8

Rear susp,left

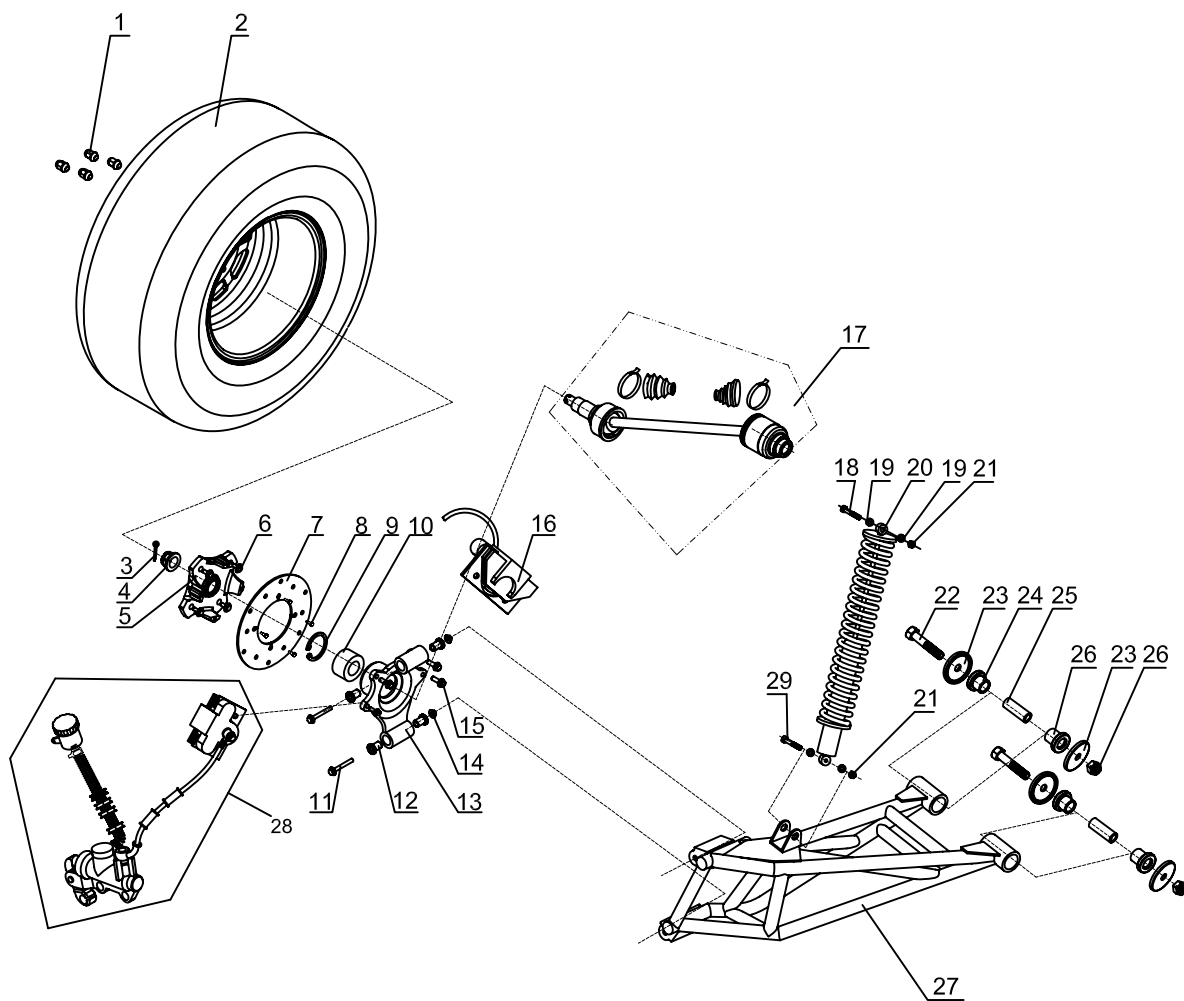

No.	Code name	Description	Q' ty
1	D650.03.02.00.02	wheel nut M10*1.25	4
2	D650.03.02.01.00	wheel(25*10-12),BL	1
3	GB/T91-2000	cotter pin 4*40	1
4	D650.03.02.00.06	slotted nut M22*1.5,rear shaft	1
5	D650.03.02.00.04	disk base	1
6	D650.03.02.00.03	M10*1.25 bolt	8
7	D650.03.02.00.05	brake disk	1
8	D650.03.02.00.08	M6 bolt ,brake disk	4
9	GB/T893.2-86	circlip55,internal	1
10	D650.03.02.00.07	bearing(Ø30*Ø50*32)	1
11	GB/T5787-86	M12*1.5*100*25 bolt	4
12	D800.02.02.00.01	bush ring	8
13	D650.03.02.00.01	bearing block	2
14	GB/T6177.1-2000	M12*1.5 nut	4
15	GB/T5787-86	M8*20 bolt	4
16	D800.07.01.01.00	four-calliper brake assy	1
17	D800.03.02.01.00	half shaft, left	1
18	GB/T5782-2000	M15*1.5*80*30bolt	1

Rear susp,left

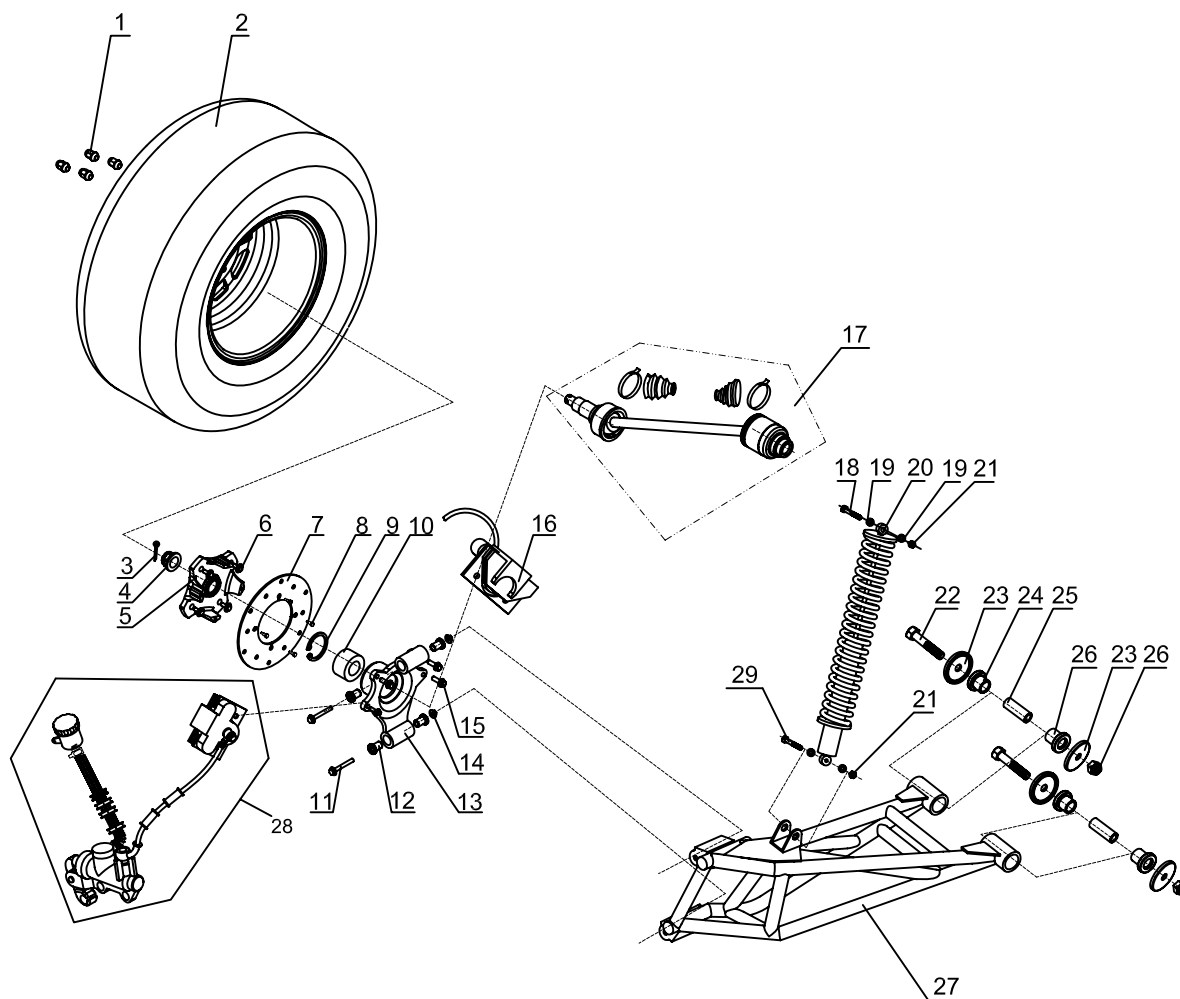

No.	Code name	Description	Q' ty
19	D800.02.03.00.03	spacer sleeve	4
20	D800.02.03.00.02	rear shock	1
21	GB/T6185.1-2000	M15*1.5 nut	1
22	GB5787-86	M16*2*125 bolt	2
23	D800.02.02.00.03	grease seal,Ø46	4
24	D800.02.02.00.02	powdered spacer sleeve	4
25	D800.02.02.00.04	spacer sleeve	2
26	GB6177.1-2000	M16*2 nut	2
27	D800.02.02.02.00	rear rocker arm,left	1
28	D800.07.02.03.00	single hydraulic park brake assy	1
29	GB/T5782-2000	M15*1.5*65*25bolt	1

Rear susp,right

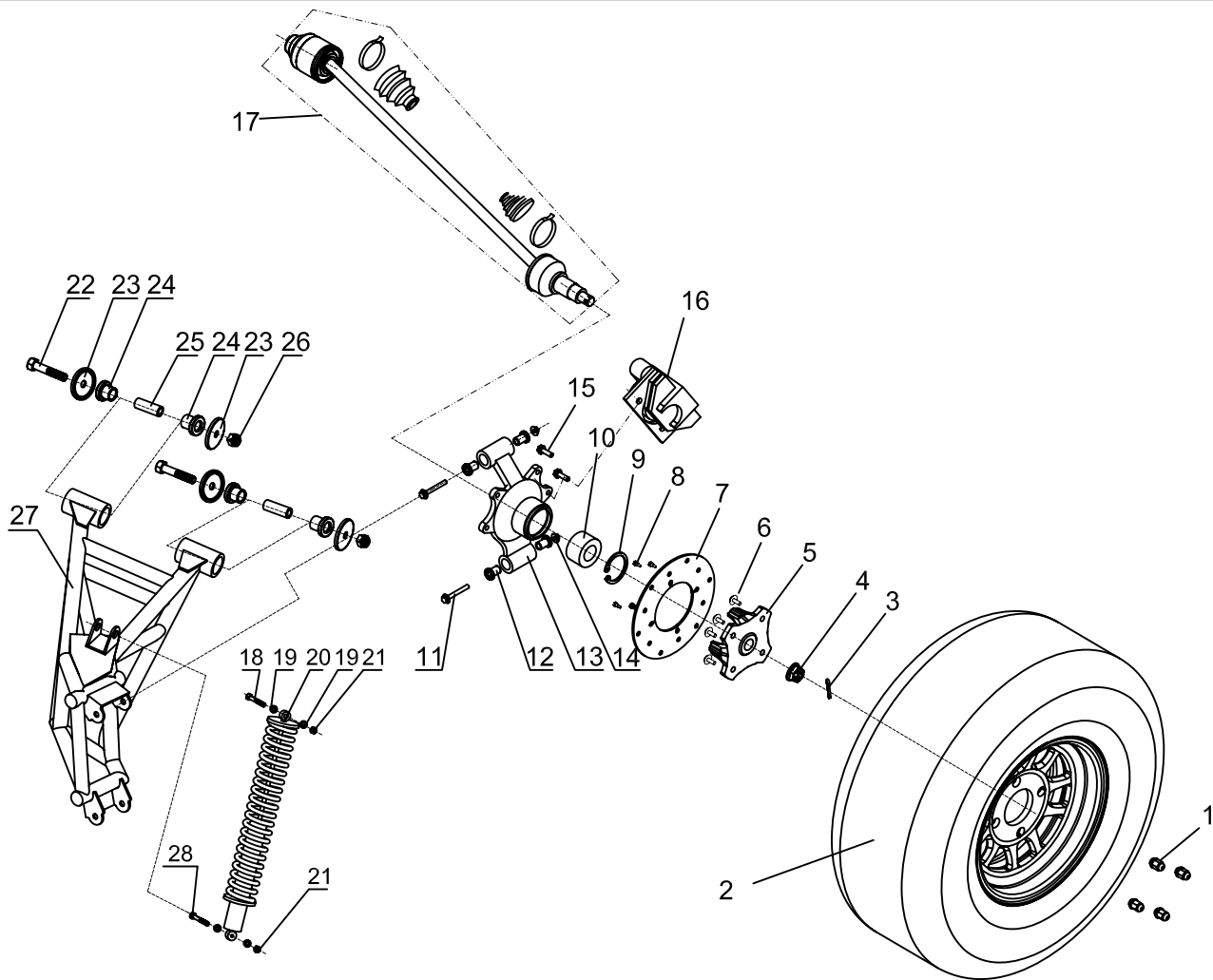

No.	Code name	Description	Q' ty
1	D650.03.02.00.02	wheel nut M10*1.25	4
2	D650.03.02.04.00	wheel(25*10-12),BL	1
3	GB/T91-2000	cotter pin 4*40	1
4	D650.03.02.00.06	slotted nut M22*1.5,rear shaft	1
5	D650.03.02.00.04	disk base	1
6	D650.03.02.00.03	M10*1.25 bolt	4
7	D650.03.02.00.05	brake disk	1
8	D650.03.02.00.08	M6 bolt ,brake disk	4
9	GB/T893.2-1986	circlip55,internal	1
10	D650.03.02.00.07	bearing(Ø30*Ø50*32)	1
11	GB/T5787-86	M12*1.5*100*25 bolt	4
12	D800.02.02.00.01	bush ring	8
13	D650.03.02.00.01	bearing block	2
14	GB/T6177.1-2000	M12-1.5 nut	4
15	GB/T5787-86	M8*20 bolt	6
16	D800.07.01.01.00	four-calliper brake assy	1
17	D800.03.02.02.00	half shaft, right	1
18	GB/T5782-2000	M15*1.5*80 bolt	1

Rear susp,right

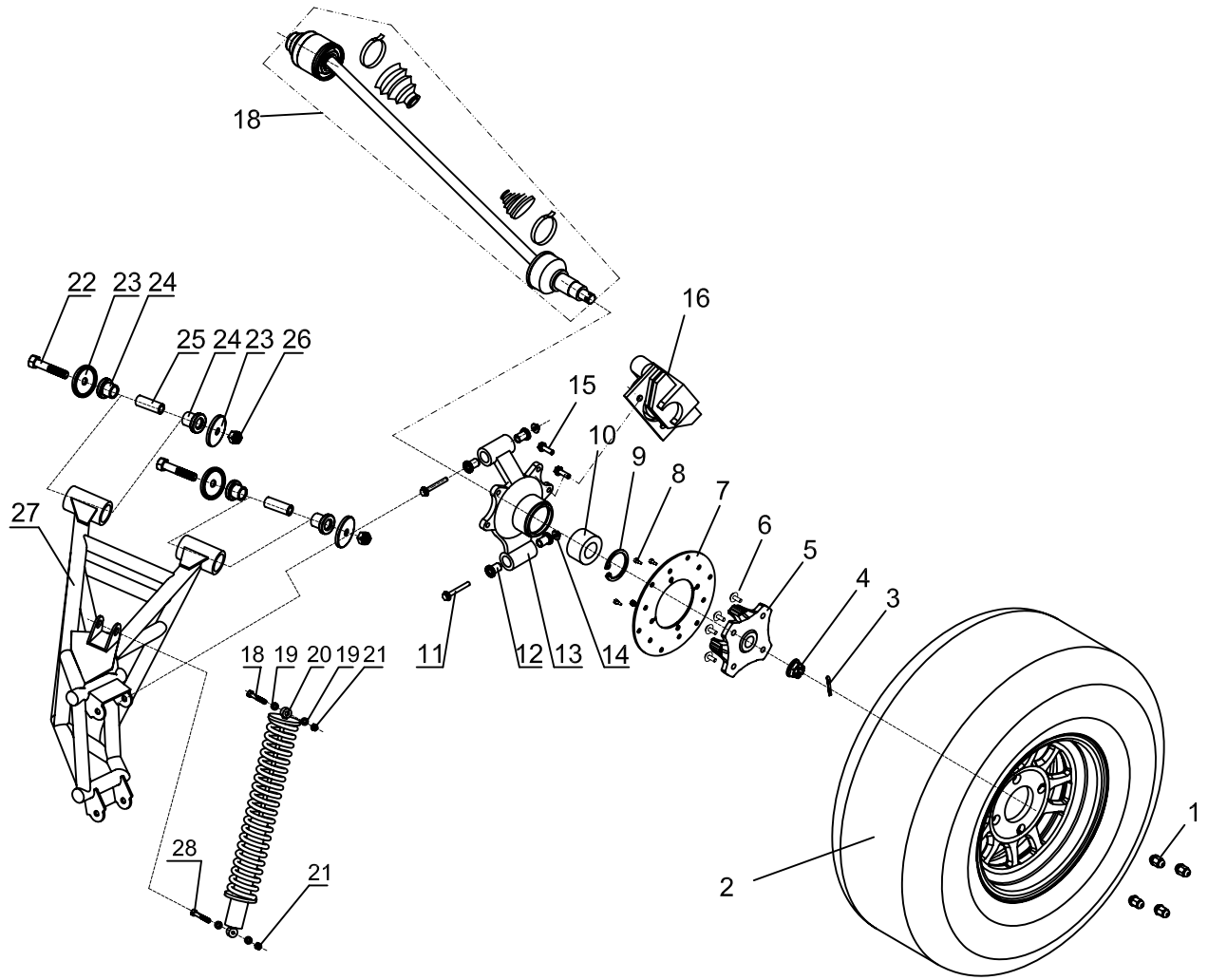

No.	Code name	Description	Q' ty
19	D800.02.03.00.03	spacer sleeve	4
20	D800.02.03.00.02	rear shock	1
21	GB/T6185.1-2000	M15*1.5 nut	2
22	GB5787-86	M16*2*125 bolt	2
23	D800.02.02.00.03	grease seal,Ø46	4
24	D800.02.02.00.02	powdered spacer sleeve	4
25	D800.02.02.00.04	spacer sleeve	2
26	GB6177.1-2000	M16*2 nut	2
27	D800.02.02.02.00	rear rocker arm,right	1
28	GB/T5782-2000	M15*1.5*65*25bolt	1

Other parts

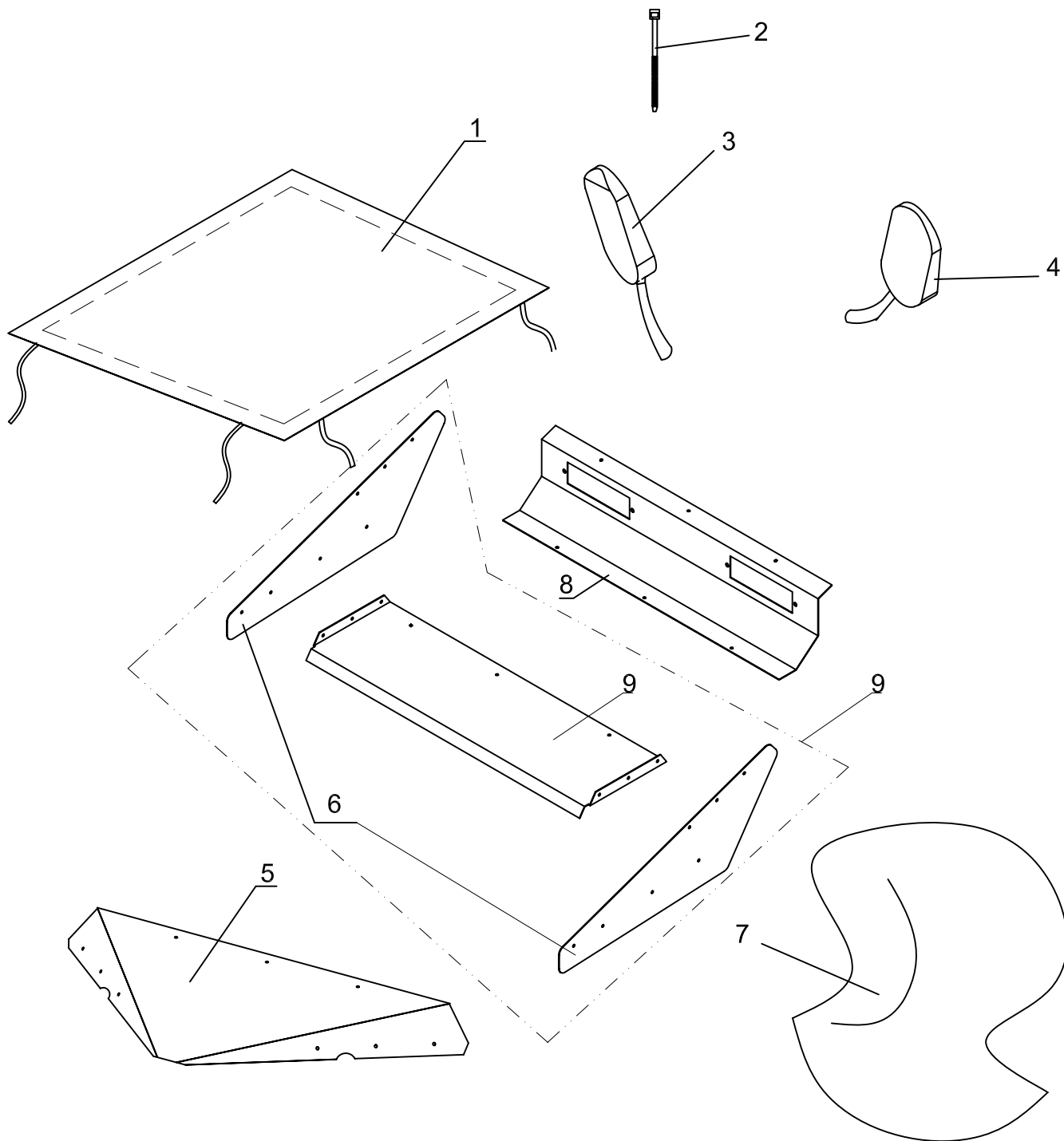

No.	Code name	Description	Q' ty
1	D800.08.01.00.02	ceiling	1
2	D650.08.05.00.06	plastic tap	
3	D650.08.01.00.06	back view mirror ,left	1
4	D650.08.01.00.07	back view mirror ,right	1
5	D800.01.02.00.01	front cover plate	1
6	D800.01.02.02.01	rear fin side	2
7	D800.08.01.00.03	cowl	1
8	D800.01.02.00.02	rear panel	1
9	D800.01.02.02.02	TOP panel	1
10	D800.01.02.02.00	empennage	1

JNSZ800DL Limited Warranty

The warranty policy applies to those cases where the new seller vehicle is unloaded from its shipping container, set up and delivered by authorized dealer, and under normal use and service is found to have defects in parts or workmanship under the following terms and conditions. This warranty covers the engine and engine related components for a period of 90 days.

This warranty does not apply to any part, which in opinion of seller was defective because of improper maintenance, improper assembly, alterations, abuse, negligence or accident.

Should warranty service be required on your JNSZ800DL during the 90 days warranty period, please contact your nearest authorized dealer for repairs.

What is not covered under this warranty

This warranty does not cover any seller vehicle that has been subjected to:

- a.** This warranty does not cover any seller vehicle in any way so to adversely affect its safety or reliability.
- b.** Renting
- c.** Disassembly, adjusting, or repairing of the vehicle in any way so as to adversely affect its safety or reliability.
- d.** Competition or racing

The warranty does not cover loss of use of the seller vehicle, loss of time, inconvenience, or other consequential damage which includes, but is not limited to, loss or damage to persons or property or any expense of returning any damaged units to the seller distributor or its authorized dealer.

Seller has the right to make changes without notice.

OWNER'S MANUAL

Page

1.	FOREWORD-----	3
2.	A FEW WORDS ABOUT SAFETY-----	4
3.	IMPORTANT SAFETY INFORMATION-----	5
4.	SAFETY LABELS-----	7
5.	ARE YOU READY TO DRIVE? -----	8
6.	IS YOUR VEHICLE READY TO DRIVE? -----	10
7.	SAFE DRIVING PRECAUTIONS -----	12
8.	SPECIFICATIONS -----	14
9.	OPERATIONS -----	15
10.	SERVICE INSTRUCTIONS -----	20
11.	REPAIR -----	24
12.	ABOUT ENGINE-----	
13.	PERIODICAL CHECK AND SERVICE -----	36
14.	WIRING DIAGRAM -----	37

.PARTS MANUAL-----

PREPARATION ATTACH INSTRUCTIONS-----

FOREWORD

Thank you for choosing JOYNER ATV. We hope you will have fun with it. Before you start to operate the ATV, please read through this Owner's Manual carefully as it contains important safety and maintenance information. Failure to follow the warnings contained in this manual can result in serious injuries.

Be sure to follow the recommended maintenance schedule and service your kart accordingly. Preventative maintenance is extremely important to the longevity of your ATV.

JOYNER believes in conservation and protection of earth's natural resources. To that end, we encourage every vehicle owner to recycle, trade in, or properly dispose of, as appropriate, used motor oil, coolant, and other fluids, batteries, and tires.

We hope you will have a pleasant experience with our products.

A FORWORDS ABOUT SAFETY

In order to keep everyone safe, you must take responsibility for the safe operation of your ATV.

To help you make informed decisions about safety, we have provided operating procedures and other information on labels and in this manual. This information alerts you to potential hazards that could hurt you or others.

It is not practical or possible to warn you about all hazards associated with operating or maintaining a ATV. You must use your own good judgment.

You will find important safety information in a variety of forms, including:

Safety Labels - On the ATV.

Safety Messages – Preceded by a safety alert symbol  and one of two signal words: **WARNING**, or **CAUTION**.

These signal words mean:



Physical harm may result from failure to adhere to the instructions that are described within the **WARNING** labels.

Safety Headings --- such as Important Safety Reminders or Important Safety Precautions.

Safety Section --- such as ATV Safety.

Instructions --- how to use this ATV correctly and safely.

This entire manual is filled with important safety information----please read it carefully.

IMPORTANT SAFETY INFORMATION

Your ATV will provide you with many years of service and pleasure. Providing you take responsibility for your own safety and understand the challenges you can meet while driving.

There is a lot you can do to protect yourself when you drive. You'll find many helpful recommendations throughout this manual. The following are a few that we consider most important.

Follow the Age Recommendation

It is strongly recommended that no one under the age of 16 be permitted to drive this ATV without adult supervision.

Always Wear a Helmet

It's a proven fact: helmets significantly reduce the number and severity of head injuries. Always wear an approved motorcycle helmet. We also recommend that you wear eye protection, sturdy boots, gloves, and other protective gear.

Drive Off-Road Only

Your ATV is designed and manufactured for off-road use only. The tires are not made for pavement, and the ATV does not have turn signals and other features required for use on public roads. If you need to cross a paved or public road, get off and walk your ATV across.

Take Time to Learn & Practice

Even if you have driven other ATV, take time to become familiar with how this ATV works and handles. Practice in a safe area until you build your skills and get accustomed to this ATV's size and weight.

Because many accidents involve inexperienced or untrained drivers, we urge all drivers to take a training course approved by the ATV Safety Institute. Check with your dealer for more information on training courses.

Be Alert for Off-Road Hazards

The terrain can present a variety of challenges when you drive off-road. Continually "read" the terrain for unexpected turns, drop-offs, rocks, ruts, and other hazards. Always keep your speed low enough to allow time to see and react to hazards.

Drive within Your Limits

Pushing limits is another major cause of ATV accidents. Never drive beyond your personal abilities or faster than conditions warrant. Remember that alcohol, drugs, fatigue, and inattention can significantly reduce your ability to make good judgments and driver safely.

Don't Drink and drive

Alcohol and driving don't mix. Even one drink can reduce your ability to respond to changing conditions, and your reaction time gets worse with every additional drink. So don't drink and drive, and don't let your friends drink and drive either.

Never run your ATV indoors.

The exhaust from the engine contains a tasteless, odorless and poisonous gas called carbon monoxide.

IMPORTANT SAFETY INFORMATION

Keep away from moving parts of the ATV

The operator of the ATV should never place their hands or other parts of their body near any moving part of the ATV. Failure to adhere to this warning will cause physical harm to your body.

Skidding or Sliding

The terrain surface can be a major factor affecting turns, Skidding a turn is more likely to occur on slippery surfaces such as snow, ice, mud and loose gravel. If you skid on ice, you may lose all directional control. To avoid skidding on slippery terrain, keep you speed low and drive carefully.

SAFETY LABELS

This section presents some of the most important information and recommendations to help you drive your ATV safely, please take a few moments to read these pages.

The labels are considered permanent parts of the ATV. If a label comes off or becomes hard to read, contact your dealer for warning labels replacements.



ARE YOU READY TO DRIVE?

Before each drive, you need to make sure you and your ATV are both ready to drive. To help get you prepared, this section discusses how to evaluate your driving readiness, what items you should check on your ATV, and adjustments to make for your comfort, convenience, or safety.

Before you drive your ATV for the first time, we urge you to:

- Read this owner's manual and the labels on your ATV carefully.
- Make sure you understand all the safety messages.
- Know how to operate all the controls.
- Never drive this ATV if under 16 years old.

Before each drive, be sure:

- You feel well and are in good physical and mental condition.
- You are wearing an approved motorcycle helmet (with chin strap tightened securely), eye protection, and other protective clothing.
- You don't have any alcohol or drugs in your system.

Protective Apparel

For your safety, we strongly recommend that you always wear an approved motorcycle helmet, eye protection, boots, gloves, long pants, and long-sleeved shirt or jacket whenever you drive.

Although complete protection is not possible, wearing proper gear can reduce the chance of injury when you drive.

The following suggestions will help you choose the proper driving gear.

Helmets and Eyes Protection

Your helmet is your most important piece of driving gear because it offers the best protection against head injuries. A helmet should fit your head comfortably and securely.

An open-face helmet offers some protection, but a full-face helmet offers more. Regardless of the style, look for a DOT (Department of Transportation) sticker in any helmet you buy. Always wear a face shield or goggles to protect your eyes and help your vision.



WARNING

Operating this ATV without wearing an approved motorcycle helmet, eye protection, and protective clothing could increase your chances of head and/or eye injury, possibly death in the event of severe accident.

Always wear approved motorcycle helmet that fits properly and wear eye protection (goggles or face shield), gloves, boots, long-sleeved shirt or jacket and long pants.

ARE YOU READY TO DRIVE?

Additional Driving Gear

In addition to a helmet and eye protection, we also recommend:

- Sturdy off-road motorcycle boots to help protect your feet, ankles, and lower legs.
- Off-road motorcycle gloves to help protect your hands.
- Driving pants with knee and hip pads, a driving jersey with padded elbows, and a chest/shoulder protector.

Drive Training

Developing your driving skills is an on-going process. Even if you have driven other ATVs, take time to become familiar with how this ATV works and handles. Practice driving the ATV in a safe area to build your skills. Do not drive in rough terrain until you get accustomed to the ATV's controls, and feel comfortable with its size and weight.



Operating ATV without proper instruction could increase your risk of an accident which could lead to serious injury or death.



Attempt supporting with your hands to the ground when the ATV turning over could lead to serious injury or death.

Never support with your hands to ground when the ATV will turn over.

Age Recommendation

It is strongly recommended that no one under the age of 16 be permitted this ATV without adult supervision.



A child driving a ATV that is not recommended for his/her age could lose ATV control and result in severe injury or death.

A child under 16 should have adult supervision when operate on the ATV.

No Alcohol or Drugs

Alcohol, drugs and ATVs don't mix. Even a small amount of alcohol can impair your ability to operate a ATV safely. Likewise, drugs, even if prescribed by a physician, can be dangerous while operating a ATV. Consult your doctor to be sure it is safe to operate a vehicle after taking medication.



WARNING

Operating this ATV after consuming alcohol or drugs can seriously affect your judgment, cause you to react more slowly, affect your balance and perception, and could result in serious injury or death.

Never consume alcohol or drugs before or while operating this ATV.

IS YOUR VEHICLE READY TO DRIVE?

Before each drive, it is important to inspect your ATV and make sure any problems you find are corrected. A pre-drive inspection is a must, not only for safety, but because having a breakdown, or even a flat tire, can be a major inconvenience.

If your ATV has overturned or has been involved in a collision, do not drive it until your ATV has been inspected by your dealer, There may be damages or other problems you can not see.



WARNING

Improperly maintaining this ATV or failing to correct a problem before driving can cause a crash in which you can be seriously hurt or killed.

Always perform a pre-drive inspection before every drive and correct any problems.

Pre-drive Inspection

Check the following items before you get on the ATV:

- Engine Oil
Check the level and add oil if needed. Check for leaks.
- Coolant
Check the coolant and add coolant if need. Check for the leaks.
- Fuel
Check the level and add fuel if needed. Also make sure the fuel fill cap is securely fastened. Check for leaks.
- Tires
Use a gauge to check the air pressure. Adjust if needed. Also look for signs of damages or excessive wear.
- Nuts & Bolts
Check the wheels to see that the axle nuts are tightened, Use a wrench to make sure all accessible nuts, bolts, and fasteners are tight.
- **Pre-drive Inspection**
- Underbody & Exhaust System
Check for, and remove any dirt, vegetation or other debris that could be fire hazard or interfere with the proper operation of the ATV.
- Air Cleaner
Check the air filter. Replace it if needed.
- Leaks, Loose Parts
Walk around you ATV and look for anything that appears unusual, such as a leak or loose cable.
- Lights
Make sure the headlight, brake light and tail light are working properly.

- Throttle
Check the free play and adjust if needed. Press the throttle to make sure it moves smoothly without sticking, and snaps back automatically when it is released.
- Clutch cable
Check the free play of clutch cable and adjust if needed. Press the clutch cable to make sure it moves smoothly without sticking, and snaps back automatically when it is released.
- Brakes
Press the brake pedal several times, check for proper brake pedal free play. Make sure there is no brake fluid leakage.
- Engine Stop
When engine is running, turn the switch key counterclockwise. Make sure engine stops.
- Steering Wheel
Check that the wheels turn properly as you turn the steering wheel.
- Cable
Check the cable housing for wear. Check the fittings are tight. Replace or tighten as needed.
- Tie rod
Check the tie rod housing for wear. Check the fittings are tight. Replace or tighten as needed.

SAFE DRIVING PRECAUTIONS

Off-Road Use Only

Your ATV and its tires are designed and manufactured for off-road use only, not for pavement. Driving on pavement can affect handling and control. You should not drive your ATV on pavement.



WARNING

Operating this ATV on paved surfaces may seriously affect handling and control of the ATV, and may cause the vehicle to go out of control.

Never operate the ATV on any paved surfaces, including sidewalks, driveways, parking lots and streets.

When driving off-road, also remember to always obey local off-road driving laws and regulations. Obtain permission to drive on private property. Avoid posted areas and obey “no trespassing” signs.

You should never drive your ATV on public streets, roads or highways, even if they are not paved. Drivers of street vehicles may have difficulty seeing and avoiding you, which could lead to a collision. In many states it is illegal to operate ATVs on public streets, roads and highways.



WARNING

Operating this ATV on public streets, roads or highways can cause collision with other vehicle.

Never operate this ATV on any public streets, roads or highways, even a dirt or gravel one.

Keep Hands and Feet on Controls

Always keep both hands on the steering wheel and both feet on the foot controls. When driving your ATV. It is important to maintain your balance and control of the ATV. Removing hands or feet away from the controls can reduce your ability to react and control the kart.



WARNING

Removing hand from Steering wheel or feet from foot controls during operation can reduce your ability to control the ATV or could cause you to lose your balance and fall off the ATV.

Always keep both hand on the steering wheel and both feet on the foot controls of your ATV during operation.

Control Speed

Driving at excessive speed increases the chance of an accident. In choosing a proper speed, you need to consider the capability of your ATV, the terrain, visibility and other operating conditions, plus your own skills and experience.



WARNING

Operating this ATV at excessive speeds increases your chances of losing control of the ATV, which can result in an accident.

Always drive at a speed that is proper for your ATV, the terrain, visibility and other operating conditions, and your experience.

Use Care on Unfamiliar or Rough Terrain

Before driving in a new area, always check the terrain thoroughly. Don't drive fast on unfamiliar terrain or when visibility is limited. (it's sometimes difficult to see obstructions like hidden rocks, bumps, or holes in time to react).



WARNING

Failure to use extra care when Operating this ATV on unfamiliar terrain could result in the ATV overturning or going out of control.

Go slowly and be extra careful when operating on unfamiliar terrain. Always be alert to changing terrain conditions when operating the ATV.

Never drive past the limit of visibility. Maintain a safe distance between your ATV and other off-road vehicles. Always exercise caution and use extra care on rough, slippery and loose terrain.



WARNING

Failure to use extra care when operating on excessively rough, slippery or loose terrain could cause loss of traction or vehicle control, which could result in an accident, including an overturn.

Do not operate on excessively rough, slippery or loose terrain until you have learned and practiced the skills necessary to control the ATV on such terrain. Always be especially cautious on these kinds of terrain.

Do Not Perform Stunts

You should always operate your ATV in a safe and reasonable manner. When driving, always keep all four wheels on the ground.



WARNING

Attempting wheelies, and other stunts increases the chance of an accident, including an overturn.

Never attempt stunts, such as wheelies or jumps. Don't try to show off.

SPECIFICATIONS

DIMENSIONS

Overall Length	122 in. (3110mm)
Overall Width	75 in. (1910mm)
Overall Height	58 in. (1480mm)
Wheelbase	105 in. (2670mm)
Front Track	66.5 in. (1690mm)
Rear Track	65in. (1650mm)
Ground Clearance	12in. (300mm)

ENGINE

Type	3-Bore,4-Stroke, Liquid-cooled
Bore x Stroke	68mm×72mm
Displacement	780 cc
Compression ratio	8.7:1
Carburetor	HGH201
Max Power	26.2kw/5300rpm
Maximum Torque	57/2500~3000Nm/r/min
Starting	Electric
Ignition	C.D.I
Lubrication	Force & Splash
Transmission	manual clutch, 4 shift/Reverse
Spark Plug	T4196J
Plug gap	0.7-0.8mm
Fuel type	RQ93 (unleaded)
Lubricate oil	SAE-15W/40

CAPACITIES

Maximum load	300kg
Fuel tank	23.0L
Engine oil	2500ml
Coolant	4000ml
Starting	<5s
Climbing	20°-25°
Battery	12V36Ah
Head Light	12V 150W/Both
Tail Light	12V 80W/Both
Fuse	30A

SPECIFICATIONS

Brake Track	< 7m @ 20miles/h
Top speed	60 miles/h (or limited as customers require)

CHASSIS

Front, Rear brake	Hydraulic disc, right foot control
Front tire	25×8-12
Rear tire	25×10-12
Front Suspension	Independent Dual A-Arm
Rear Suspension	Longitudenal Control Arm
Final Drive	shaft driven

TIRE PRESSURE

Front	70kpa 0.7kg/c m ² 10psi
Rear	70kpa 0.7kg/c m ² 10psi

WEIGHT

Net Weight	555kg
------------	-------

WARRANTY

OPERATION

A. Operation controls

WARNING-Do not attempt to start or operate the engine until completely familiar with the location and use of each control necessary to operate this vehicle. The operator must know how to stop this machine before starting and driving it.

a. Throttle

The right foot pedal is the throttle that controls the ATV speed. To disengage the clutch at any time, allow the throttle to return to the idle position. (See Fig. 1)



Each time prior to starting the engine, check the throttle assembly to ensure that when pedal is pushed all the way forward the assembly is working smoothly and returns to idle when released. Do not operate if pedal or engine throttle linkage fail to return to idle. If unable to correct the problem through lubrication, adjustment or replacement of worn parts, contact your dealer for assistance.

b. Brake

The brake is located on the middle of the three control pedals (See Fig. 1). Applying pressure to the pedal applies pressure to the brake caliper around the brake disc at the front and rear wheels and slows or stops the kart.

c. Clutch

The left foot pedal controls the clutch cable (See Fig. 1). With the pedal down, you can shift the shift lever.



Improper operation of the clutch will lead to excessive wear of the clutch friction surface.

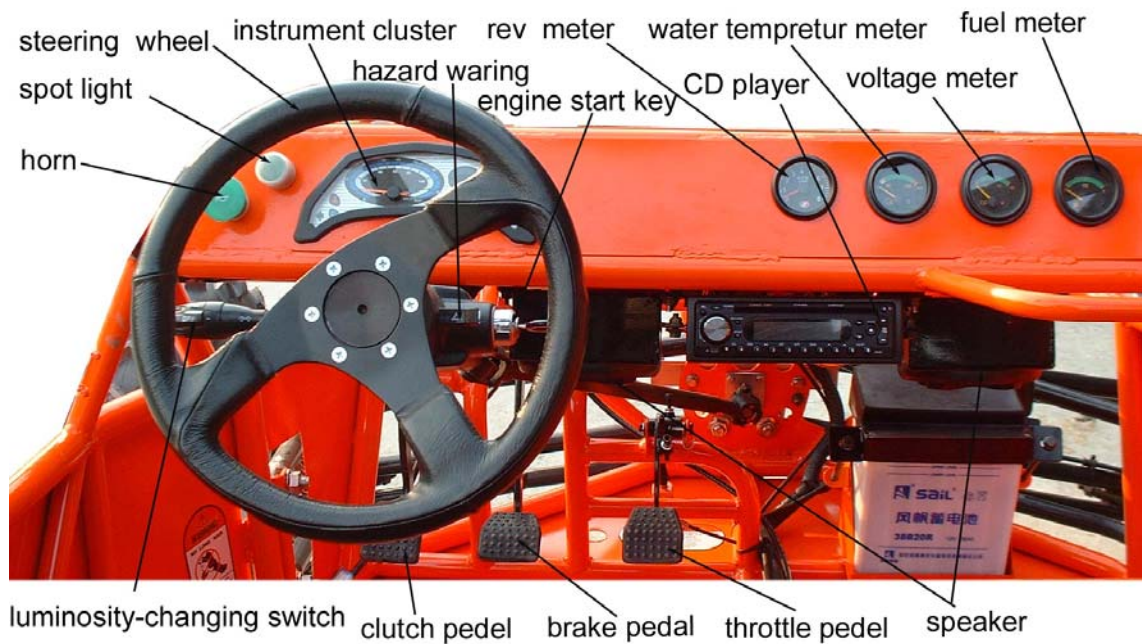

Fig. 1

d. Start engine

1. Engage the park brake
2. Press the clutch pedal down, put the shift lever in neutral
3. Insert the key into the ignition-switch

OPERATION



Fig. 2

If the engine is cold;

1. Pull the choke out fully
2. Press down the clutch pedal
3. Turn the key clockwise to the “on” position. Release the key and the clutch pedal when the engine starts.



Fig. 3

4. Push the choke back slowly to allow the engine to run smoothly. Keep engine running for 1-2 minutes.
5. Push the choke back fully. If the idle of engine is not smooth, pull out the choke to find the best running position and keep running for a while long until the engine runs smooth without choke.

If the engine is warm;

Press the throttle slightly and turn the key clockwise to the “on” position, release the key and the throttle when the engine starts.



Each time prior to starting the engine, check the throttle assembly to ensure that when pedal is pushed all the way forward the assembly is working smoothly and returns to idle when released. Do not operate if pedal or engine throttle linkage fail to return to idle. If unable to correct the problem through lubrication, adjustment or replacement of worn parts, contact your dealer for assistance.



Before you start the engine, check that the parking brake is engaged, and the gear shift lever is in neutral. Trying to start the engine in gear may damage the starter motor, clutch or gearbox.



Release the key at once if the key in start position when the engine is running will cause damage to the starter motor.



If the engine does not start after 10 seconds, a second attempt to start the engine can be allowed. Improper operation will damage the engine.

e. Engine stop key

Important-stop key test.

Before driving this vehicle, test the Engine Stop key to assure that it is operating properly. With the engine running, turn the key counterclockwise to the “off” position for the engine to shut down.

B. Pre-Drive Inspection



Perform this pre-drive inspection everyday before driving vehicle. If not performed, serious damage to the vehicle or personal injury may result.

1. Check for Engine Oil Level. Check for transmission Oil Level. Check for leaks, add oil if required.
2. Check the coolant. Check for leaks, add the coolant if required.
3. Check for Fuel Level. Add fuel as necessary and do not overfill. Check for leaks.
4. Check for Brakes. Depress the brake pedal several times, and then check for proper brake pedal free play. Make sure there is no brake fluid leakage. Adjust if necessary.
5. Check the clutch cable, Assure the cable snaps back and has a smooth operation. Ensure the clutch can operate smoothly. Adjust if necessary, or replace the clutch if necessary.
6. Check Tires. Check tires condition and pressure. The pressure on both Front and Rear tire is 12psi.
7. Check Throttle. Check for smooth operation. Ensure the throttle “snaps” back to idle.
8. Check Engine Stop key. Perform engine stop key test. Repair as necessary.
9. Check all Nuts, Bolts, and fasteners. Check wheels to see that all axle nuts and lug nuts are tightened properly. Check and tighten as necessary all other fasteners to specified torque.
10. Check Roll Cage Bars. Ensure all protective roll cage bars are in place before operating the ATV.

OPERATION

12. Check Brake Light. Check for proper operation.
13. Check Wheels. Check for tightness of wheel nuts and axle nuts; check that axle nuts are secured by cotter pins.
14. Check Steering. Check for free operation and for any unusual looseness in any area.



Always follow rules for safe operation and wear a helmet.

C. Passengers

The vehicle allows for two riders only. Combined maximum weight of driver and the passenger should not exceed 180kg or 400lbs.

D. Seat Adjustment

The seat must always be securely fastened in the position which best allows the operator control of the foot pedals, steering wheel, and the remote stop key.

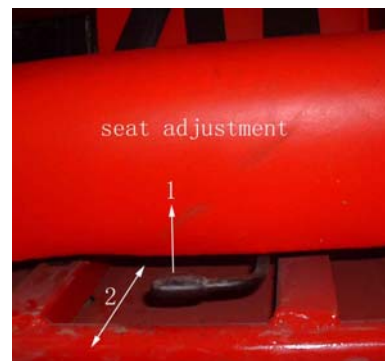

Fig. 4

- a. Pull seat adjustment handle upward to disengage seat slide.
- b. Move seat to desired position.

- c. Be sure seat adjustment handle snaps back into place and that seat is locked into position. (See Fig. 4)



WARNING

Before attempting to adjust the seat ensure that engine of the ATV is stopped.



WARNING

Never operate this ATV when the provided seat is not securely fastened, to do so could result in a strong possibility of severe personal injury or loss of life. Before attempting to adjust the seat ensure that engine of ATV is stopped.

OPERATION

E. Parking Adjustment(See Fig. 4)



Park brake "OFF"



Park brake "On"

Fig.6

- Pull the park brake lever up so that the unit can engage park brake.
- To release the unit, press button on front end of parking lever then push the parking lever to the bottom.
- Adjust the parking cable if necessary.

F. Gear Shift Adjustment

- Loosen the bolts.
- Press down the clutch pedal fully.
- Operate the shift lever as to change gearshift from 1 to 4 and reverse smoothly.
- First, tighten bolt 1 with thread glue. Then second, tighten

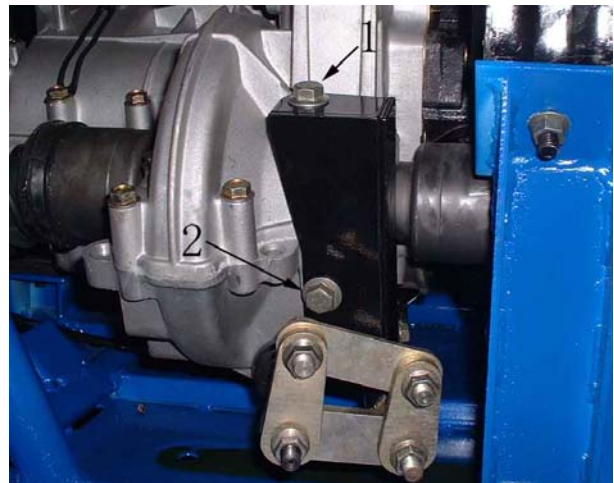

bolt 2 with thread glue.
(See Fig. 7)

Fig. 7

G. Break-in

The first month is most important in the life of your vehicle. Proper operation during this break-in period will help assure maximum life and performance from your new vehicle. The following guidelines explain proper break-in procedures.

1. After the engine starts, the engine is not allowed in high speed in the neutral gearshift.
2. Drive vehicle from stop to low speed slowly.
3. Avoid braking strongly.
4. Do not exceed the vehicle speed on the below schedule

The speed of vehicle	The first 1000 km		
Max speed in each gear	1st	Gear	25km/h
	2nd	Gear	45km/h
	3rd	Gear	70 km/h
	4th	Gear	100km/h

OPERATION

H. Starting And Operating Instructions

- a. Before starting the engine, be sure that the driver is seated properly in the ATV and tighten the seatbelt.
- b. Testing the ATV in a open place at the beginning to learn how to start, turn and stop.
- c. Operate the ATV slowly until you are familiar with it.
- d. The turning radius of this ATV is small and agile, so the centrifugal force is very high when turning at high speed. Slow down to a more controllable speed when turning to prevent the ATV from rolling over.
- e. To prevent vehicle from rolling over, be sure to only turn the vehicle at a slow more controllable speed.

SERVICE INSTRUCTIONS

A. Service Air Filter

Service air filter every 80 hours

NOTE: Service more often under dusty conditions.

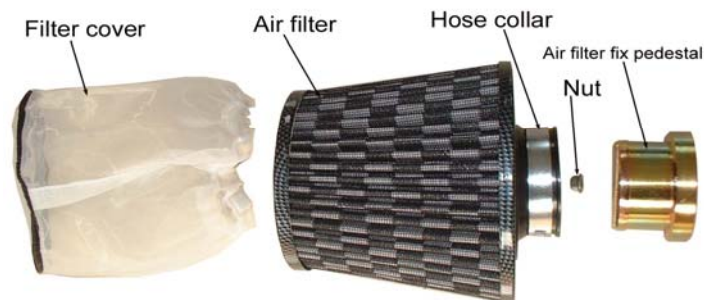

Fig.8

- a. Remove filter cover(See Fig. 8)
- b. Check the filter cover and the air filter, if the filter cover and the air filter is dusty, please clear the filter cover and replace with a new air filter.

B. Engine Lubrication

Engine oil replacement

You must change the oil in the crankcase after the first 5 hours of operating of your new engine and after 10 hours of use thereafter. That will insure proper lubrication of internal parts and prevent costly repairs due to excessive wear.

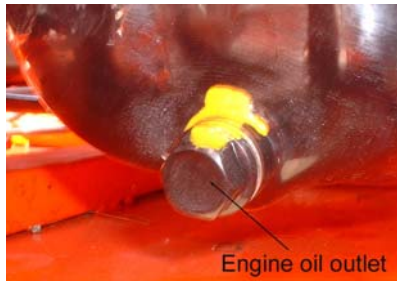

Figure 9



Figure 10

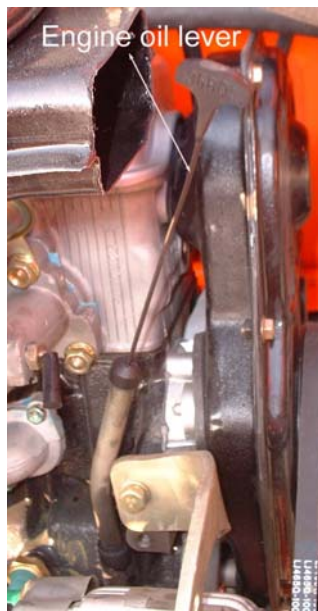

Figure 11

SERVICE INSTRUCTIONS



Figure 12

- a. With the engine warm, put the vehicle on the level ground.
- b. Shut down the engine, put a collecting oil plate under the engine oil outlet. Loosen the oil outlet plug in the warm engine. Let the engine oil out fully (see Fig. 9).
- c. Tighten the engine oil outlet plug.
- d. Remove the oil filler cap (see Fig. 10), fill oil (SE 15W/40 or SF 15W/40) about 3.5 liters to the engine.
- e. Pull out the engine oil dip stick (see Fig. 11), confirm the corrective oil level in the crankcase (see Fig. 12).

Check engine oil and recharge

- a. If the color of engine oil changes, you need to replace the engine oil. Replace the engine oil as above.
- b. Check the engine oil level, change if necessary from **d** as above.

C. Transmission lubrication

You must change the oil in the transmission after the first 5 hours of operating of your new engine and after 10 hours of use thereafter. That will insure proper lubrication of internal parts and prevent costly repairs due to excessive wear.



Fig. 13



Fig. 14

SERVICE INSTRUCTIONS

- a. Put the vehicle on the level ground.
- b. Shut down the engine, put a collecting oil plate under the transmission oil outlet. Loosen the oil outlet plug in the warm engine. Let the transmission oil out fully (see **Fig. 14**).
- c. Remove the iron dust plug, this plug has a magnet on it. Iron dust caused by moving parts will stick to the plug. Clean the iron dust from this dust plug.
- d. Tighten the transmission oil outlet plug and the iron dust plug.
- e. Remove dipstick of transmission (see **Fig. 13**), fill oil (**GL-4 85W/90**) about 1.9 liters.
- f. Insert the transmission dipstick, check the oil level in the transmission. Confirm the corrective oil level in the transmission (see **Fig. 13**).

Check transmission oil

If the color of transmission oil changes, you need to replace oil. Replace transmission oil as above.

D. Engine Coolant

You must check the coolant for level and leaks. If it is low, you need to refill coolant into the radiator (approximately 4000 ml). The lack of coolant will cause the engine to overheat. This can cause engine damage.

The coolant should always be topped up, since the coolant can evaporate.



Figure 15



Figure 16

Put the vehicle on level ground.

1. Turn the coolant cap counterclockwise and open the cap (see Fig. 15).
2. Pour fresh coolant to filler neck.
3. Start the engine at idle.
4. Increase the engine rev's a few times
5. Repeat 2,3,4 till the coolant is at neck and no bubbles come up.
6. Refit the coolant cap, turn it clockwise and tighten it
7. Turn the reserve coolant case counterclockwise and open the cap (see Fig. 16).
8. Pour fresh coolant of the specified type into the reserve coolant tank till the coolant reaches 2/5 to 3/5 of the reserve coolant tank volume.
9. Close the reserve coolant case cap, turn it clockwise and tighten it

Top up the reserve coolant

If the coolant in the reserve tank is less than 2/5, it needs to be topped up.

1. Turn the reserve coolant case cap counterclockwise and open the cap.
2. Pour fresh coolant of the specified type into the reserve coolant tank till the coolant reaches 2/5 to 3/5 of the reserve coolant tank volume.
3. Close the reserve coolant case cap, turn it clockwise and tighten it

SERVICE INSTRUCTIONS

! WARNING

Opening the radiator cap while the engine is hot can be hazardous. Opening the radiator cap can spray the high temperature coolant in your eyes, face and any parts of your body. This can result in severe injury. Never open the radiator cap while the engine is hot.

! WARNING

New and used coolant can be hazardous. Children and pets may be harmed by new or used coolant. Continuous or brief contact with coolant may be dangerous for your health. Keep new and used coolant away from the children and pets. To minimize your exposure to new and used coolant, wear a long sleeve shirt and moisture-proof gloves (such as dishwashing gloves) when you change coolant. If coolant contacts your skin, wash thoroughly with soap and water. Wash any clothing or rags if wet with coolant. Recycle or properly dispose of used coolant.



WARNING

Failure to use the correct coolant or coolant not the same as one in the radiator or reserve case can harm your ATV. Engine damage may occur if you use coolant that does not meet the specifications.

F. Carburetor Adjustment

Never make unnecessary adjustments. The factory recommended settings are correct for most applications. It's not necessary to disassemble the screw unless the carburetor needs to be replaced. Prepare a 50r/w tachometer before adjustment.

- a. Warm up the engine (5~10min)
- b. Tighten the air screw gently. Back out 2-3/8 turns counter clockwise (see Fig. 17).
- c. Connect the tachometer, adjust the throttle to limit the idle speed. The standard value is (1400RPM).
- d. Turn the air screw counter slowly and observe the RPM of the engine, stop adjusting as the RPM reaches the top speed.
- e. Adjust the screw and adjust the idle speed to an ideal value.
- f. Repeat step **d** and **e** until the rotate speed of engine stables.

SERVICE INSTRUCTIONS

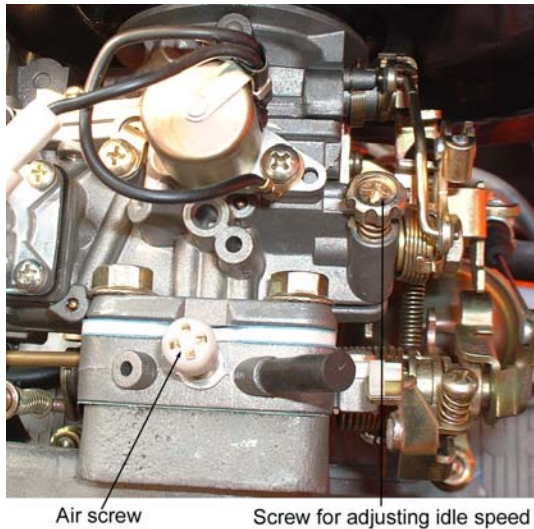

Fig.17

G. Cleaning Instructions

Keep your kart clean. With a clean rag, wipe off and dirt and oil from around controls. Wipe off any spilled fuel and oil. Keep the engine clean of foreign object and be sure to check that air intake fan is free of debris for proper cooling.

H. Kart Lubrication

Lubricate vehicle every 90 days of use, Apply several drops of oil in specific points.

I. Storage Instruction

In the event your kart is not to be operated for periods in excess of 30 days or at the end of each driving season prepare for storage as follows:

- a. Drain fuel tank and carburetor by allowing engine to run out of fuel, or use a fuel stabilizer.
- b. Lubricate engine cylinder by removing the spark plug and pour one ounce of clean lubricating oil through the spark plug hole into the cylinder. Crank the engine slowly to spread oil and replace spark plug.
- c. Do not save or store gasoline over winter. Using old gasoline, which has deteriorated from storage, will cause hard starting and affect engine performance.



WARNING

Do not drain fuel while engine is hot. Be sure to move ATV outside before draining fuel.

REPAIR

A. Clutch replacement

Do not remove the whole engine from vehicle when you replace the clutch, but you'll need to remove rear suspension, driven shaft, clutch cable, muffler, wires and rubber cushion that is in the middle of transmission and frame.

1. Remove bolt M14 (See Fig. 18)



Fig. 18

2. Remove two bolts (M12) on the starter (See Fig. 19), Remove the starter (See Fig. 20)



Fig. 19



Fig. 20

REPAIR

3. Remove two nuts (M14) on two side of transmission (See Fig. 21, 22)



Fig. 21



Fig. 22

5. Remove two bolts(M8) on the low mud plate of transmission (See **Fig. 23, 24**)

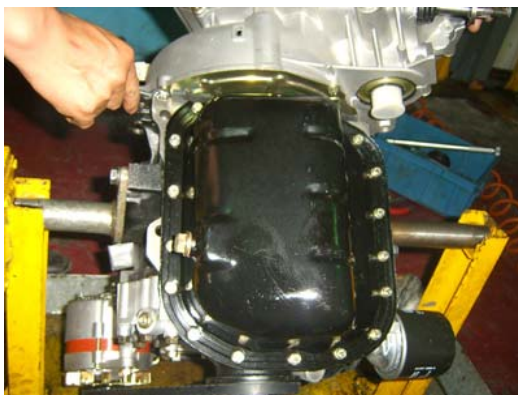

Fig. 23



Fig. 24

6. Remove the mud plate (See **Fig. 25**).



Fig. 25

REPAIR

7. Remove the transmission (See **Fig. 26, 27**)



Fig. 26

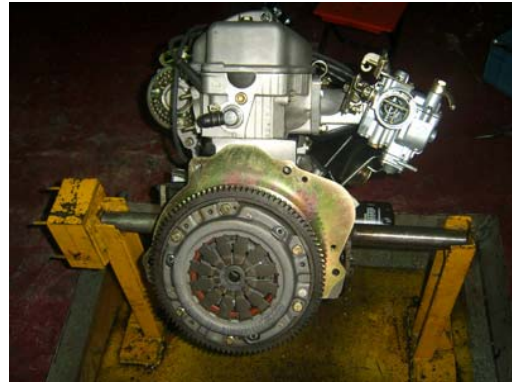

Fig. 27

8. Remove upper mud plate (See Fig. 28)



Fig. 28

REPAIR

9. Insert a shaft into the hole (See Fig. 29). Remove six bolts on the pressing plate of

clutch (See Fig. 30)



Fig. 29



Fig. 30

10. Remove the pressure plate (See Fig. 31).

Remove the friction disc of clutch (See Fig. 32, 33)



Fig. 31



Fig. 32



Fig. 33

REPAIR

10. Insert a special shaft into the hole, fix new friction plate on the flywheel of engine

(See Fig. 34, 35).



Fig. 34

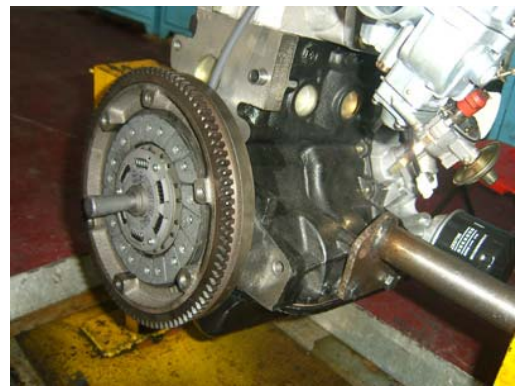

Fig. 35

11. Fix pressure plate of clutch. Two bolts with “Y.G” mark must be inserted into two anchor hole (See Fig. 36) . Tighten six bolts with torque 30 N.m (See Fig. 37)



Fig. 36



Fig. 37

12. Fix upper mud plate (See Fig. 38, 39)



Fig. 38



Fig. 39

13. Fix parts according to reverse operation to the disassembly

D. Front Wheel Alignment

1. Put the vehicle on level ground.
2. The “toe-in” of the front wheels should be 0.9 inches. To check for alignment,

measure distance A and B between the centerline (CL) of the wheels. The proper toe-in dimension A should be 1.18 inches greater than dimension B.

3. To adjust the alignments, loose the lock nuts on both sides of Front Tie Rods. To make Dimension B smaller, turn the rod to the left. Turn the rod to the right to make Dimension B larger. After adjusted to desired length, tighten the lock nut against the rod end. Recheck the dimensions for proper alignment.

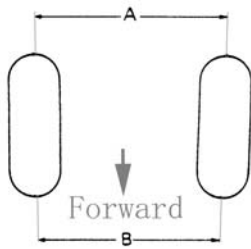

About engine

A. precaution

- a. strictly observe all requirements and specifications in this manual.
- b. Check the earth polarity of accumulator. this gasoline engine adopts negative earth.
- c. Grinding in must be conducted when using a new gasoline engine.
- d. When gasoline engine is running, your head, hand, cloth, tool and other things should be strictly forbidden to approach the running fan and pump belt.
- e. When running or just stopping, don't touch exhaust sub-tube etc heat exhaust parts. Don't open radiator cover when it is hot.
- f. When starting gasoline engine, you must not throttle fiercely in order to avoid running at a high speed and too low fuel pressure.
- g. When running at a high speed and overload, don't stop engine. You should stop it after it runs at a low speed for 3-5 minutes.

B. Grinding in of new gasoline engine and its precautions.

New gasoline engine must be grinded in before using it normally. it should be mounted on a car and driven for 1000km according to the running criteria in table 1 or grinded in on the gasoline engine test platform for 50 hours according to the grinding in criteria

Grinding in of new gasoline engine and its precautions

Engine oil, fuel ,coolant, and electrolyte of accumulator should be sufficient. Don't operate it at high speed at once after starting the engine. You should preheat it step by step.

You'd better drive it on cement pavement or asphaltum pavement, and avoid running on soil sand road as little as possible.

Don't exceed the high speed that asked in table 1.

After driving for 1000km, the new car can be used normally.

Check the valve clearance, firing advance angle, idle, tightness of water pump belt, then adjust them to meet the manual requirement.

Change filter, lubricant of gasoline engine, gearbox and differential.

Screw tightly connecting bolt of cylinder cover, every bracket bolt , admission and exhaust sub-tube bolt or nut.

C. Care and maintenance of gasoline engine

- a. Periodical care and maintenance item

Periodical care and maintenance table

Table 2

No	Maintaining period item	1000m	1	10	20	30	40	50	60	70	80
		month	1	6	12	18	24	30	36	42	48
1	Water pump belt		JT		JT		G		JTG		JT
2	Timing belt		JT		JT		JIG		JIG		JIG
3	Admission and exhaust valve clearance		JT		JT		JT		JT		JT
4	Engine bolt and admission and exhaust sub-tube nut		N		N	N	N	N	N	N	N
5	Engine oil filter		G	G	G	G	G	G	G	G	G
6	coolant						G				G
7	Soft tube and joint of cooling system				JTG		JTG		JTG		JTG
8	High voltage resistant wire				JTG		JTG		JTG		JTG
9	Distributor cover and rotor				JTG		JTG		JTG		JTG

10	Spark plug and distributor platina contacting point		G	G	G	G	G	G	G	G
11	Firing timer	J.T	J.T	J.T	J.T	J.T	J.T	J.T	J.T	J.T
12	Advancer of distributor firing			JIG		JIG		JIG		JIG
13	Gasoline oil tube and joint	JT				JIG				JIG
14	Gasoline filter					G				G
15	idle	JT		JT		JT		JT		JT
16	Gearbox lubricant	G	JG	JG	JG	G	JG	JG	JG	G
17	air soft tube and joint cylinder cover			JIG		JIG		JIG		JIG
18	Gasoline engine oil	G	Change it once per driving 5000km							
19	Air filter	Clean it once per running on 10000km asphalt road, 2500km on dust road. change it once per running 40000km or always keep it clean.								
20	Throttle wire and carburetor shaft	Get J.T.G per running 1000km								

**Note: J: check T: adjust G: change N: screw tightly
filter: the changing time can be shorten according to the dirty extent of engine oil.**

b. The main tightening torque of gasoline engine

No.	Description of parts	Tightening torque (N.m)
1	Cylinder cover connecting bolt	55-60
2	Valve rocker adjusting nut	18-22
3	Spark plug	20-30
4	Main bearing cap bolt of crankshaft	43-48
5	Connecting rod cap nut	28-32
6	Flying wheel bolt	40-45
7	Timing sheave bolt of crankshaft	50-60
8	Timing sheave bolt of camshaft	50-60
9	Tensioner bolt	18-22
10	Admission and exhaust sub-tube bolt and nut	18-28
11	Cylinder cover shield bolt	6-8
12	Oil plate bolt	7-9
13	Bleeding screw plug of oil pan	30-40
14	Cylinder cover bolt	18-28
15	Connecting bolt and nut of gearbox and crankcase	48-54

c. care and maintenance of lubricating system of gasoline engine

1. choice of lubrication

The user choose lubrication must consider the temperature in which it is used, according to fig 3 which give the proper using range of the lubrication, choose API grade of SE,SD,SF, it marked

About engine

QE grade 20W-40 gasoline engine lubrication by producer. It is shown as **fig. 40**

1) -----20w-40-----

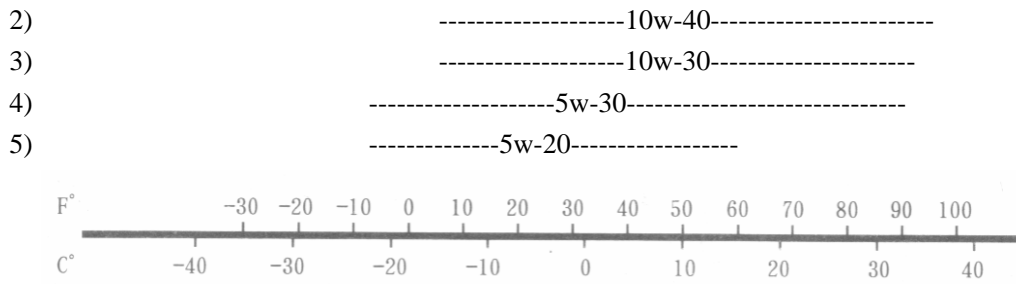

Fig. 40

2. The oil level of gasoline engine oil pan should be between upper scale and lower scale. it is shown as in **fig.41**

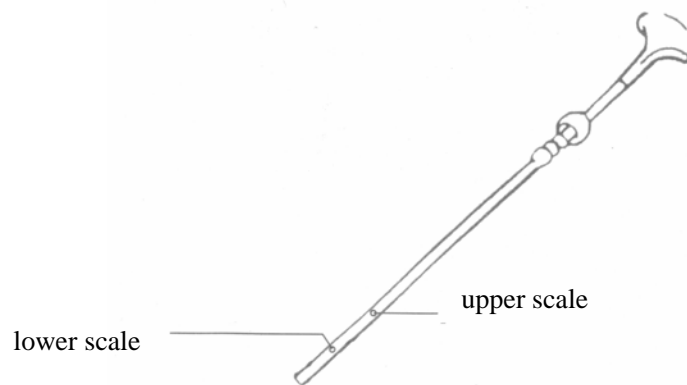

fig. 41

When measure the oil level, the gasoline engine should be in the installing position of the car (the car is in level position), if the color of the lubrication has changed much, it should be changed.

2. before filling lubrication, take off the filling oil hole cover ,then fill in lubricant ,it is shown as **fig. 42**. after finished it ,make the engine in idle for 3-5 minute and check the oil level once per three minutes.

About engine

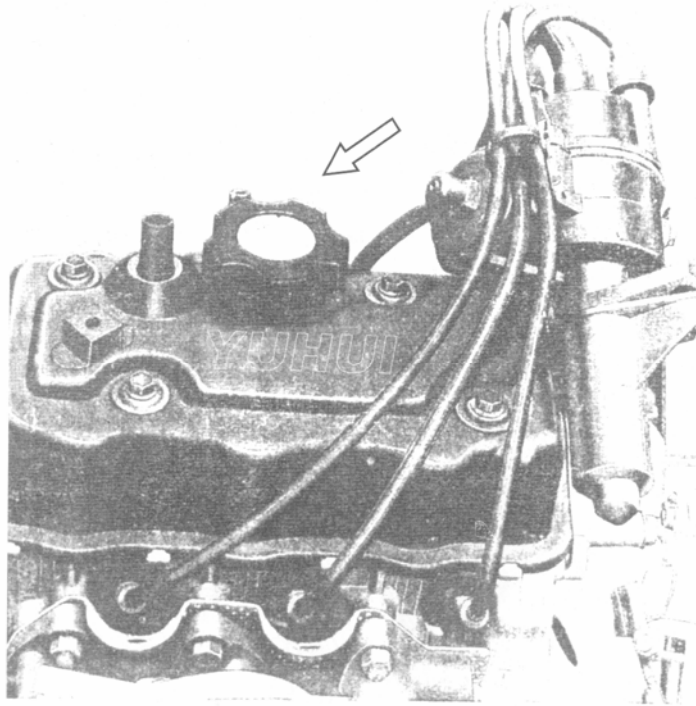

fig. 42

4. Change the lubrication should be conducted under the hot status of gasoline engine . unscrew the bleeding screw plug on the bottom of oil pan ,after bleeding all original oil and remount the bleeding screw plug according to specified torque, it is shown as **fig. 43**.

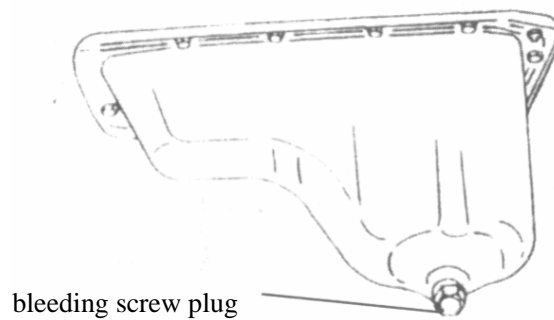

fig. 43

5. choose lubrication for gearbox's gear oil AP/GL-4 SAE 75W/85,85W,80W/90 or 90. When fill in lubrication, the oil scale should be taken out at first, then fill in lubrication. the oil level should be between upper scale and lower scale.(See **fig.44**)

About engine

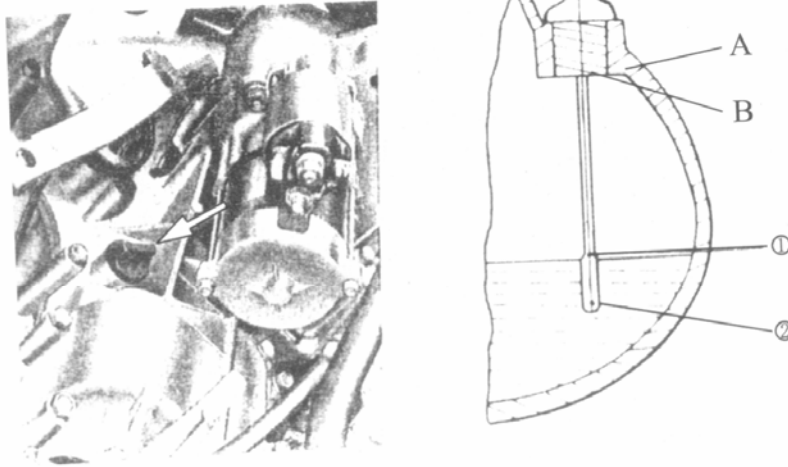

fig.44

6 . Check lubrication pressure of gasoline engine

when gasoline engine running at idle, lubricant pressure warning lamp should be lighted off. or otherwise, it indicates the pressure too low, and you should stop engine and check it ,and see whether it is sufficient, and the oil road whether it is leak or jammed. Check the engine oil screen and filter whether they are jammed.

d. Care and maintenance of cooling system

1 . Coolant of gasoline engine is glycol water antifreeze mixture. Don't use antifreeze mixture with different character, river water and well water etc. coolant amount should be enough (3.6L), coolant add-in amount should be up to the scale "full". If the level is lower, you should add in on time.

2. check and adjust belt of water pump

Apply 98N pressure in the position which is in middle of the between water pump belt and generator belt, its bending deflection should be 7.5-11.5mm, it is shown as **fig. 45**.

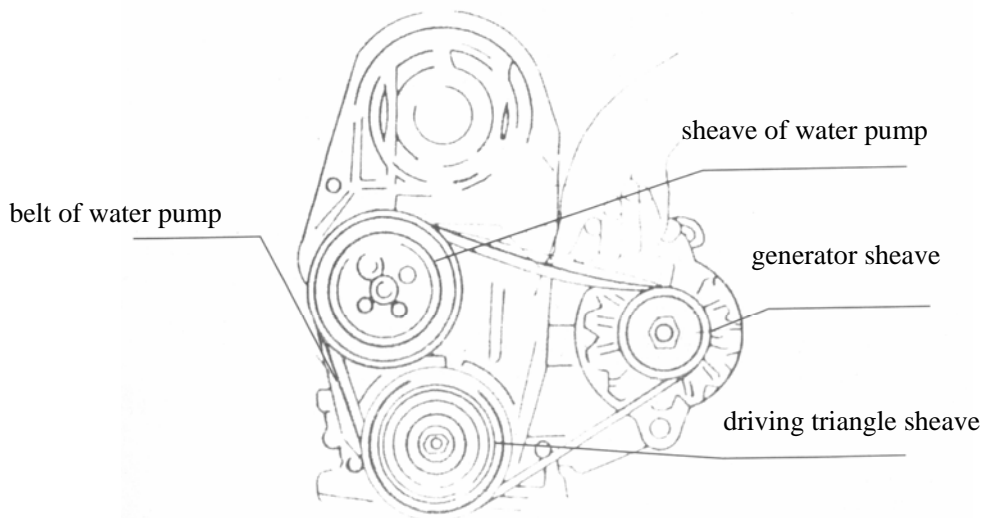

Fig. 45

About engine

Method of adjusting and changing belt of water pump:

Unscrew the three fixed bolts of generator, pressing generator outward can tight the belt or inward loose it. It is shown as **fig. 46**. after adjusting or change, the tightness of belt meets the above mentioned requirement, screw the three fixed bolts of generator tightly.

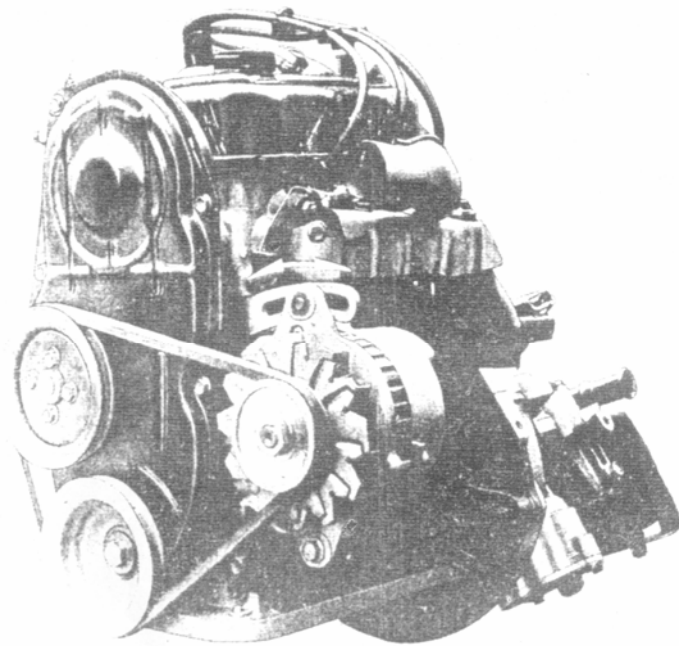

Fig .46

e. care and maintenance of firing system

1. the surfaces of the two poles of spark plug should be clean and flattening. You should often remove the carbon deposit between the two poles. The clearance should be adjusted as 0.7-0.8mm, and it should be even on the overall pole plane, shown as in **Fig .47**. when you change spark plug, you should note its type is T4196J.



Fig .47

2. The end faces of the three contacts of distributor should be clean, without any oil stain and other foreign matter. the end face of the two platina contacts of end face should be flattening, and should be on parallel position and keep it clean. the clearance should be 0.4-0.5mm, shown as **Fig .48**. if you can not meet the demand, you should loose ①two fixed screws ②adjust it.

About engine

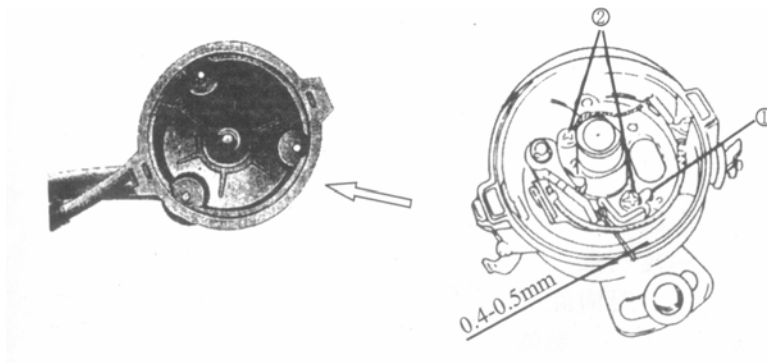

Fig .48

f. Checking and adjusting of valve mechanism

1. Check the mounting position of timing belt

Remove the front shell of timing belt and rotate crankshaft clockwise in order to align the key slot center (mark1) and round dot “ . ” (mark 4) on the sheave of camshaft with “ ↑ ” (mark 5) on the rear shell assembly. At this time ,the key slot center (mark 3) and round dot “ . ” (mark 6) on the timing sheave of camshaft should be matched with “ ↓ ” (mark 7) on the rear shell assembly, as shown in **Fig .49** . or otherwise, you should adjust it until it is aligned. At this time, the first piston (close to fan)should be in the upper dead point of compression stroke, i.e. there should be a clearance between admission exhaust valve and rocker adjusting screw.

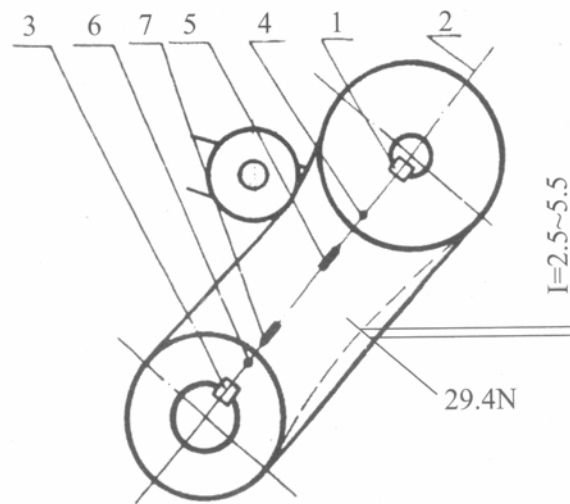

Fig .49

2 . Change of timing belt

The timing belt with excessive wear, aliation and off-teeth should be changed.

When changing it, loose the rocker nut and make adjust screw back to position where camshaft can turn in order to avoid the valve impacting the piston .Then lose the two fastening belts of tensioner and remove the belt. When mounting it, you should adjust the positions of the two timing sheaves according to **Fig .49** and confirm the alignment of 2,1,4,5,7, 6 and 3. the mark should be on a straight line. When there is no loosing on the position “8” of diagram, mount it keeping the arrow mark on the back of timing belt in the direction of running clockwise and make it tighten by depending on the acting force of tensioner spring, and confirm the assembly position whether if has met requirements in **Fig .49** by turning the crankshaft clockwise by two rounds. then screw the

tensioner belt tightly.

3. Checking and adjusting valve clearance

The clearance between admission valve and exhaust valve is 0.13-0.18mm under cold status. when measuring the clearance, you should make the work circle of rocker lean against the base circle of cam, shown as in **Fig .50**.

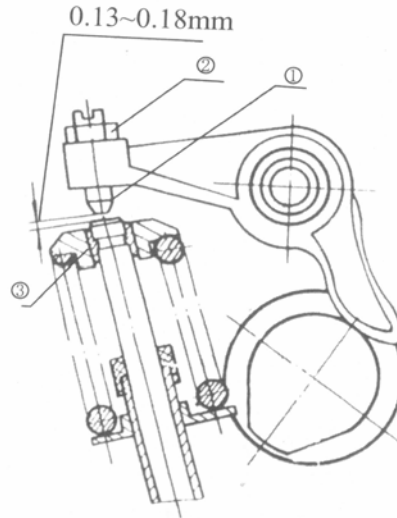

- ① adjusting bolt of rocker
- ② rocker nut
- ③ valve rod

Fig .50

When adjusting valve clearance, make the key slot center of timing sheave of camshaft connect with the mark “.” On the flange. the connecting line corresponding to the mark “↑” on the back cover and camshaft center should be 0° , 120° , 240° , and confirm that the cambered surface of work circle of rocker has leaned against the base face circle of cam. And then adjust the clearance between admission valves and exhaust valves of cylinder 1,3,2 in turn. shown as in **Fig .51**.

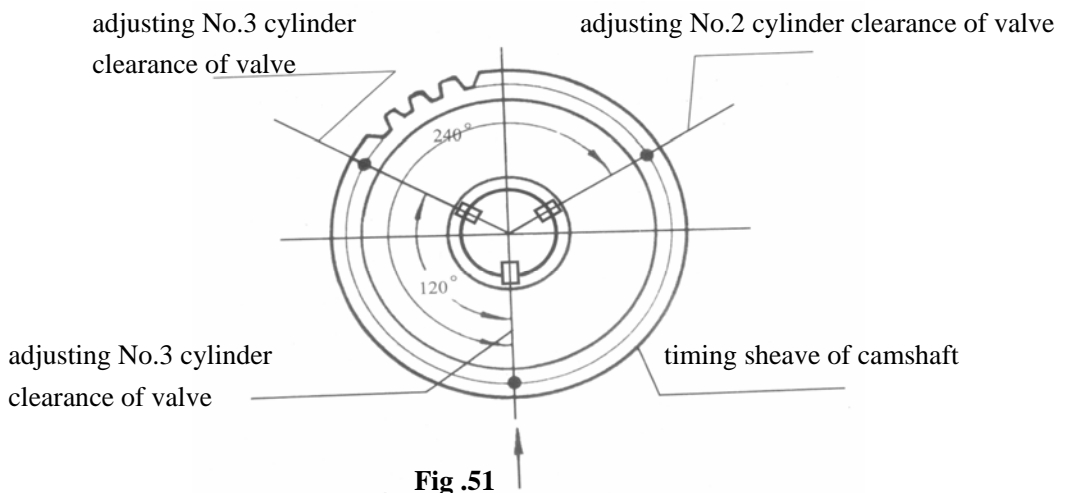

Fig .51

g. Check and adjust firing advance angle

1. According to shown as in **Fig .52**, it should be .4-0.5mm. check clearance of platina contacts of distributor firstly, if it can not meet demand, you can unscrew the fastening bolts ①② of the distributor and adjust them.

About engine

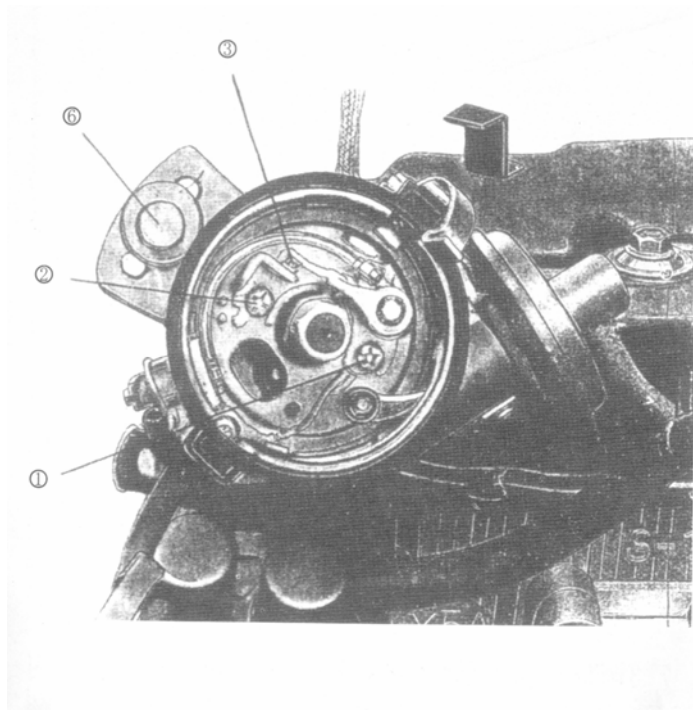

Fig .52

2. Check firing advance angle by starting firstly gasoline engine under idle(900 ± 50 r/min) .Use timing lamp to light the flywheel viewing-hole of gearbox by connecting the lamp with the high voltage resistant wire of the first cylinder, shown as in **Fig .53**.The timing mark on the flywheel 7° should be aligned with the timing finger of the bracket, the tolerance should be $\pm 1^\circ$,or otherwise you should adjust it.

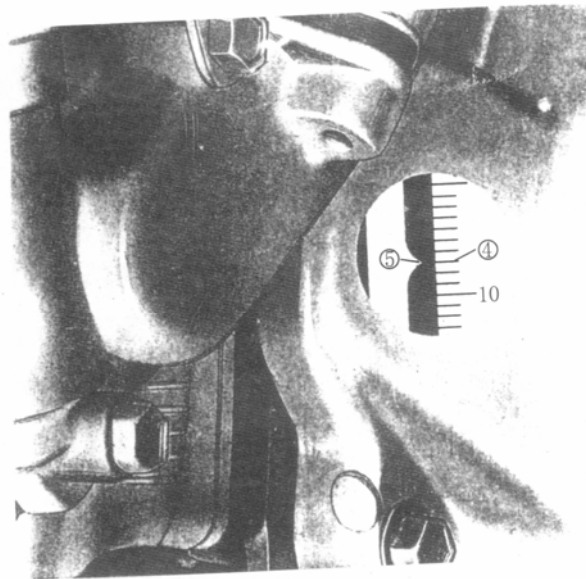

Fig. 53

3. Adjust the firing advance angle by loosening the fastening bolt of distributor⑥ shown as in **Fig. 53**.Rotate the distributor clockwise to enlarge the advance angle or vise verse. After finishing the adjustment, fasten distributor and check it with timing lamp. The firing advance angle should be within $7^\circ \pm 1^\circ$.

C.Main trouble and solutions of gasoline engine:

See attached list

D.Storage of gasoline engine

There is a small quantity of lubricant in YH368 gasoline engine when it left factory. It should be stored in clean, dry and ventilated warehouse without any corrosive gas. Storage period should be half a year.

If period of storage were longer than half a year, you should fill 2.5L antirust lubricant into gasoline engine and remove spark plug of all cylinder, and make all piston be between upper dead and lower dead point, and fill 0.006L antirust lubricant into every cylinder and start gasoline engine for 3-4 times using start motor. Each time is about 15 seconds long. And then remove bleeding screw plug and spark plug, and screw them tightly according to the specified torque.



ORDER PARTS

<https://gokartsusa.com/800cc-Go-Kart-Buggy-Engine.aspx>

PERIODICAL CHECK AND SERVICES

The maintenance intervals in the following table are based upon average driving

conditions. Driving in unusually dusty areas, require more frequent servicing.

Item \ Time of service	Initial service	Monthly	Quarterly	Yearly
Engine				
1. Fan, driven belt		I	I	R
2. Tighten bolts on engine.	I		I	
3. Engine oil	I		I	
4. Coolant			I	
5. Coolant hose and joints	I		I	R
6. Exhaust		I		I
7. Transmission oil		I	R	
Ignition				
8. Coil			I	
9. Distributor for ignition			I	
10. Air cleaner			C	I
11. Throttle cable and choke		I.A.L		I.R.A
12. Fuel tank cover. Breathe hose and joint.		I	I.R	
13. Idle			I	
14. Breathe hose			I	
15. Fuel hose and joints	I	I	I.R	
Control system				
16. Wire and plugs			I	
17. The free display of clutch pedal		I		I.R
18. Brake fluid, hose, joints			I	
19. The free display of brake pedal, Brake	I	I	I	I
20. Parking			I	
21. Brake shoes and disc			I	I.R
Chassis				
22. Tires		I		R
23. Tighten nuts on the hub and wheel	I	I	I	
24. Shocks			I	
25. Driven shaft		I		I
26. All nuts and bolts	I	I	I	I
27. Steering wheel, steering	I		I	
28. Test vehicle	I	I	I	I

A: adjust **C:** clean **I:** inspect, clean or replace if necessary. **L:** lubricate **R:** replace

WIRING DIAGRAM

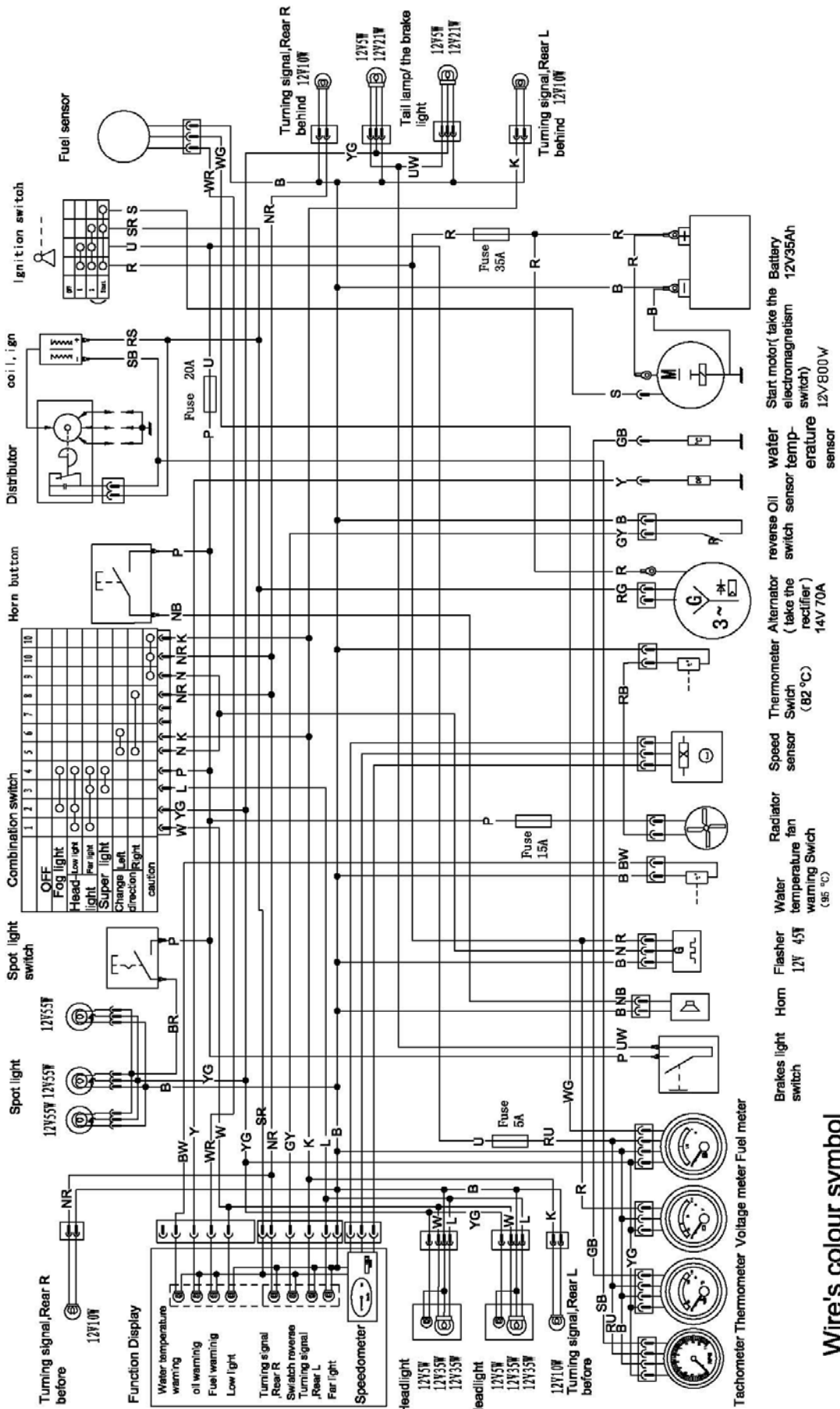

Wire's colour symbol

- RS—red/grey B—black R—red U—blue RU—red/blue P—purple S—grey W—white YG—yellow/green L—Cambridge blue N—brown K—pink NB—brown/black NR—brown/red
- UW—blue/white RB—red/black GY—green/yellow SB—grey/black BR—black/red Y—yellow WG—white/green GB—green/black WR—white/red BW—black/white